

# *Deficit Irrigation of Quality Winegrapes Using Micro-Irrigation Techniques*



**Terry Prichard, Irrigation and Water Management Specialist**  
**Blaine Hanson, Irrigation and Drainage Specialist**  
**Larry Schwankl, Irrigation Specialist**  
**Paul Verdegaal, Viticulture Farm Advisor**  
**Rhonda Smith, Viticulture Farm Advisor**

**University of California Cooperative Extension**  
**Department of Land, Air and Water Resources**  
**University of California Davis**  
**April 2004**

The preparation of this handbook was made available through a grant from  
the Lodi-Woodbridge Winegrape Commission, Lodi, California

# Table of Contents

## **A. Introduction**

- Introduction
- Irrigation Scheduling Concepts
  - The Benefits of Irrigation Scheduling
  - Deficit Threshold Irrigation

## **B. Soil Water Reservoir**

- Soil Water Holding Capacity
  - Soil Texture
  - Soil Structure
- Root Zone Depth
  - Root Distribution
  - Determining the Vineyard's Effective Root Zone

## **C. Measuring Water Sources**

- Soil Moisture Content and Tension
- Available Soil Moisture
- Measuring Soil Moisture
  - Soil Sampling
  - Tensiometers
  - Electrical Resistance Blocks
  - Neutron Moisture Meters
  - Dielectric Soil Moisture Sensors
  - Sensor Placement and When to Measure
- Measuring In-season Rainfall
  - In Season Effective Rainfall
- Measuring Irrigation Water
  - Flowmeters
  - Measuring Emitter Discharge

## **D. Vine Water Deficits Caused by Reduced Soil Water Availability**

- Winegrape Water Use
- Vine/Fruit Growth and Development
- Effects of Vine Water Supply on Vine, Fruit and Wine
- Vine Water Deficits Caused by Reduced Soil Water Availability
- Timing of Water Deficits
  - Early Season Deficits
  - Pre-Veraison Deficits
  - Post-Veraison Deficits
  - Post Harvest Deficits

## **E. Developing a Deficit Irrigation Strategy**

- Regulated Deficit Irrigation (RDI)
- Deficit Threshold Irrigation (DTI)
  - Experiences with Deficit Threshold Irrigation
- Selecting an Appropriate Deficit Threshold and RDI
  - Selecting a Deficit Threshold
  - Selecting a Post Threshold RDI %

**F. Methods for Determining When to Begin Irrigation**

- Visual and Measurements
  - Shoot Growth
  - Shoot Growth Rate
  - Tip Ratings
- Using the Pressure Chamber in Winegrape Irrigation Scheduling
  - When to Sample
  - Factors that Influence Leaf Water Potential
  - Operation and Use of the Pressure Chamber
  - Vine Selection
  - Sample Number
  - Leaf Selection
  - Sample Collection
  - Measurement
  - Problems
  - Reproducibility

**G. Developing the Irrigation Schedule**

- Defining Mature Vineyard/Site Conditions
- Determining How Much to Apply
  - Estimating Full Potential Water Use
  - Evapotranspiration Reference Values
  - Crop Coefficient ( $K_c$ )
  - Calculating Full Potential Water Use with Historical Average  $E_{to}$
  - Calculating the Water Use Using the Regulated Deficit % (RDI%)
  - Accounting for the Soil Contribution and Effective Rainfall
  - Determining the Weekly Vine Irrigation Volume
  - Adjusting the Schedule for the Current Season's Climate

**H. Applying Irrigation Water**

- Irrigation Water Units
- Determining the Irrigation Amount

**I. Monitoring Vine Performance to Evaluate Strategy**

- Post Threshold Midday Leaf Water Potential
- Vegetative Growth
- Yield
- Fruit Quality

**Appendix**

- Drip System Evaluation Form
- Sample Data Sheet for Drip System Evaluation Form
- Average Weekly Non-Rain  $E_{to}$ , Lodi, CA CIMIS Stations # 42 and #166
- Sample Irrigation Scheduling Worksheet
- Sample Irrigation Scheduling Worksheet for Lodi, CA

## A. Introduction

### *Introduction*

The main purpose of controlling the application of irrigation water to winegrapes is to produce high quality fruit. The volume of irrigation water required to produce high quality fruit varies from year to year, depending primarily on the extensiveness of the vine canopy, the soil resources, and climatic conditions of both the previous winter and current season. However, regardless of the exact volume of applied water, the goal is to ensure irrigation produces the desired effect on the vine and fruit. Controlling irrigation application often results in supplying less water than the full potential water requirement of the vineyard. This practice is known as deficit irrigation.

Each vineyard can be very different in location (climate), soil-water capacity, vigor and trellis design. Production goals may also depend on the variety and wine program to which the fruit is destined. Each of these factors exclusive of irrigation can significantly affect both the production level and fruit quality. The first step towards producing high quality fruit is to balance vine vegetative and reproduction structures. This is best done through vineyard design, which includes proper selection of rootstock, variety/clone, planting density, and trellis design for a particular location, soil, and climate. Once planted and the vines are mature irrigation can be used to maximize fruit quality. Unfortunately, even with the best development plans, vegetative growth can be excessive causing reduced fruit quality. In these cases an irrigation strategy utilizing water deficits can be adopted to optimize fruit yield and quality. Deficit irrigation is the management of irrigation, which causes vine water deficits to occur. Various timings and severity of the deficits can be used to achieve specific vineyard objectives.

This publication presents a method of deficit irrigation, which allows growers to determine WHEN to begin irrigation and subsequently to determine HOW MUCH water to apply. It presents some of the effects of deficit irrigation strategies upon the vine and fruit. Growers of quality winegrapes can use the information and experiences herein presented to determine their own irrigation strategy in pursuit of their individual vineyard goal.

### *Irrigation Scheduling Concepts*

#### *When and How Much*

An irrigation-scheduling program should determine when to irrigate and how much water to apply to achieve specific objectives. The objective most often expressed is to have a predictable influence on vine growth, yield, and fruit quality.

Yields of most crops are directly related to the volume of consumed water. Therefore, full potential water use (all the plant can use) is desirable. Maintaining adequate but not excessive soil moisture can successfully accomplish scheduling for these crops for the entire season. Soil moisture monitoring methods or estimates of crop water use is commonly utilized to schedule irrigations. However, the production of quality winegrapes usually requires the use of an irrigation strategy that provides for less than full potential vine water use. Additionally, it may be desirable to use a strategy, which causes water deficits to occur at specific times and of different

deficit severities. This calls for a different scheduling methodology, which can regulate the amount and timing of water deficits.

### **Water Sources**

Vineyards can use water from a variety of sources. These most typically include soil stored moisture, effective in-season rainfall and irrigation. Other water sources can include ground water from shallow or intermittent water tables. All of these sources combine to supply the appropriate quantity of water for optimal vine performance.

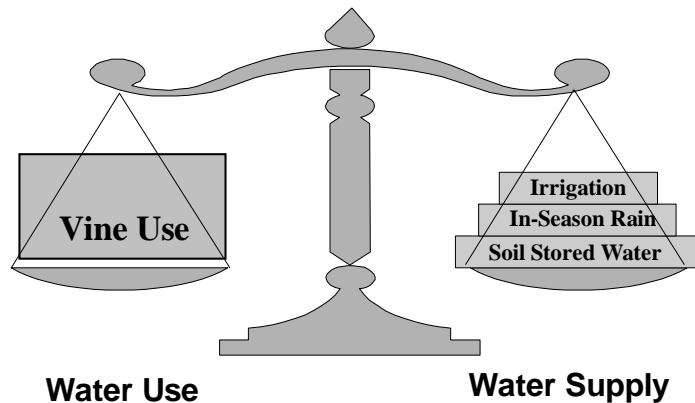

### ***The Benefits of Irrigation Scheduling***

- Reduced costs (energy and water).
- Control of excess vegetative growth.
- Reduced cost of hedging and multiple leaf removal.
- Reduced disease (bunch rot)
- Increased fruit quality
- Reduced environmental risks (off site and percolation movement)
- Reduced fertilizer losses (deep percolation)

### ***Deficit Threshold Irrigation.***

There are many approaches to deficit irrigation in terms of the timing and severities of the water stress the vine experiences. These different approaches include early water stress, a constant reduction in irrigation volumes in relation to full water potential use, or a cutoff of irrigation before harvest just to name a few.

This publication focuses on a method called “Deficit Threshold.” This method was developed from a number of research projects in which the goal was to improve fruit quality and maintain yields. Deficit threshold is a type of regulated deficit irrigation (RDI) where irrigation is withheld until a level of vine water stress is attained then followed by a specific volume of irrigation to allow continued sugar accumulation and preserve canopy cover. This practice controls excessive vegetative growth allowing diffuse light into the fruiting area improving fruit color and character while minimizing yield reductions.

## B. Soil Water Reservoir

### *Soil Water Holding Capacity*

Water in the soil resides within soil pores in close association with soil particles. The largest pores transport water to fill smaller pores. After irrigation, the large pores drain due to gravitational forces leaving water held by the attraction of small pores and soil particles. Soils with small pores (clayey soils) will hold more water per unit volume than soils with large pores (sandy soils). After a complete wetting and time is allowed for the soil to de-water the large pores, a typical soil will have about 50% of the pore space as water and 50% air. This is a condition generally called field capacity or the full point. Soils dry down from field capacity to a point where water becomes too difficult for the root to extract. The remainder of the water held in the soil is unavailable to the plant.

### *Soil Texture*

Soil consists of mineral particles, organic matter, air, and water. The mineral particles are classified by size as sand, silt, and clay. Sand particles are the largest size, and the clay particles, the smallest. The relative proportion of these sizes determines the soil texture.

Soil texture affects the water-storage capacity of soil and the rate at which water infiltrates into and flows through soil—all characteristics important for irrigation water management. Sandy soil stores a relatively small amount of soil moisture but has high infiltration rates. Clay soil stores more moisture, but has slow infiltration rates.

Proportions of sand, silt, and clay in soil are determined by first passing the soil through a series of sieves of progressively smaller sizes and measuring the amount of sand retained on each sieve. Silt and clay particles are not retained on the sieves. Percentages of silt and clay are determined by measuring the settling rates of these particles in water.

Once percentages of sand, silt, and clay categories are determined, *Figure B-1* is used to identify the soil textural classification. For example, soil with 55 percent sand, 15 percent silt, and 30 percent clay would be classified as sandy clay loam.

Soil is frequently designated as “coarse-textured” or “fine-textured.” *Table B-1* assigns the textural classes to broad categories of coarse-, medium-, and fine-textured soil.

Figure B-1 Proportion of sand, silt, and clay in the basic soil-textural classes

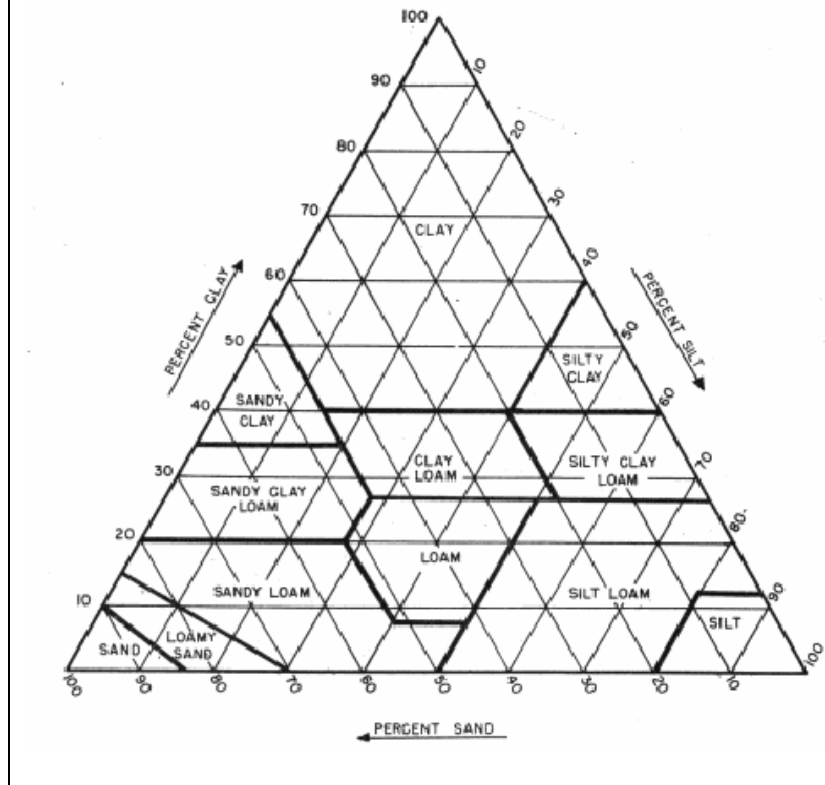

Table B-1. General terms for basic soil textural classes.

General Terms			Available Water Holding Capacity	
Sandy soils	Coarse-textured soils	Sands	0.7	
		Loamy sands	1.1	
Loamy soils	Moderately coarse-textured soils	Sandy loam	1.4	
		Fine sandy loam	1.5	
		Medium-textured soils	Very fine sandy loam	1.5
			Loam	1.8
			Silt loam	1.8
Clayey soils	Fine-textured soils	Silt		
		Clay loam	1.6	
		Sandy clay loam	1.3	
		Silty clay loam	1.9	
		Sandy clay	1.6	
		Silty clay	2.4	
Clay	2.2			

## *Soil Structure*

### *Structure*

Soil structure refers to the arrangement of the soil particles. Sand particles are larger and more spherical than the smaller silt and still smaller plate-like clay particles. The voids between particles (called pores) serve as a conduit to move water and air into the root zone. Cultivation and compaction from farming equipment or that occurred during soil development decreases the total porosity and changes the distribution of pores from predominately macro to micro pores. Compaction causes a decrease in the large pores and an increase in small pores. Soil compaction, and pore plugging which occurs during soil development decreases water holding capacity, infiltration rate, and air reentry.

## *Root Zone Depth*

### *Root Distribution*

Vine roots can explore deeply into soils if limiting layers are not encountered. Vine water use in deep, well-aerated soils has been reported to depths of 20 feet. Rooting depth in vineyards located in shallow soils or those with root zone limiting conditions can be much less. In low rainfall areas and irrigated frequently with micro-irrigation systems, vines may not develop a deep root system even if soil conditions are not limiting.

### *Root Limiting Conditions*

Root depth limitations caused by soil texture and structure can be grouped into three categories:

- Fine textured soils with poor internal drainage characteristics and/or poor structure
- Soils with dense, compact, or cemented sub-soils
- Layered or stratified soils where abrupt, significant changes in soil texture may disrupt water movement in the vicinity of the interface

Other root limiting conditions:

- Rock
- The existence of a water table whether static or fluctuating can limit the depth of the root zone. Roots may grow into the deeper depths when the water recedes however, they may die back when the water table rises.

### *Rootstock*

Rootstocks vary in their rooting habit. Some have an extensive, shallow root system and therefore are very effective in removing shallow moisture but will be less effective in extracting deep moisture. Water deficits can occur more quickly on rootstocks such as 5C, 5BB and 1103. Rootstocks such as Dog Ridge, St. George, Freedom, and 110R are reported to be more effective in scavenging for deep moisture.

## *Determining the Vineyard's Effective Root Zone*

Excavating the soil between the rows with a backhoe is commonly used to both physically view the root distribution and check for the cause of a root-limiting factor. All vines have a greater root density in the shallow soil depths declining with depth. It is easy to be convinced that the root zone is shallower than it is when only a few roots are found at the deeper depths. The root density is normally less at deeper depths but they are

still functional if moisture is available. The use of moisture measuring devices can help define the root zone over the season by monitoring the soil water disappearance at soil depths in and below the suspected root zone. Drought conditions and or continued deficit irrigation where the deep soil is never wetted can reduce the number of deep roots over time. Young vineyards will increase the size of the root zone over time and will be influenced by the type of irrigation system and irrigation frequency and the amount of winter rainfall. If these conditions exist, a reevaluation of the effective root zone is necessary to confirm the current rooting depth.

Soil moisture measuring devices can be used to determine effective root zone depth. Care should be taken to monitor at depths deeper than the expected root zone depth. *Figure B-2* shows the water content in soil depths from 9 to 108 inches from bud break to leaf drop in a non-irrigated vineyard. Results show very little water extraction at or below the 57-inch level.

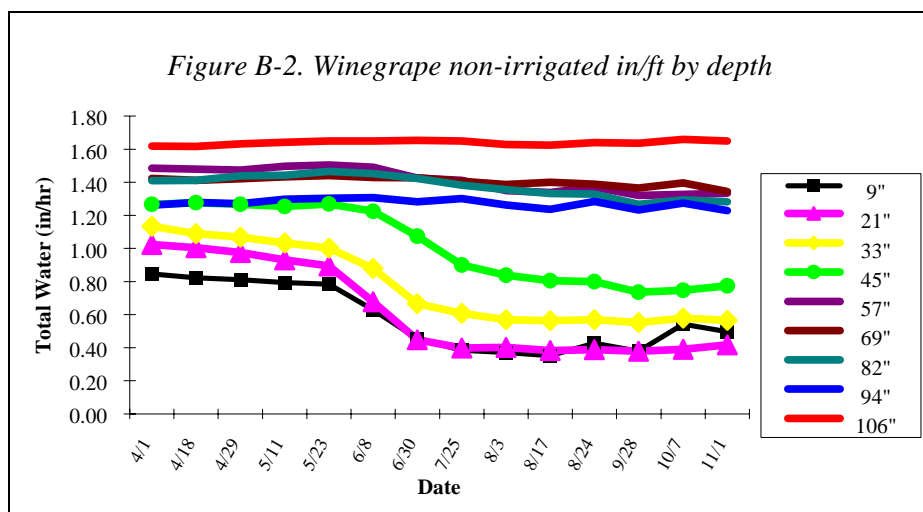

**Water Tables**

Static water tables can limit root growth due to saturated soil conditions. Fluctuating water tables can allow growth when the soil is not saturated then kill roots when re-saturated. Shallow water tables whether static or fluctuating can contribute water to the vines water use. As the soil dries above the saturated soil, water moves up into the unsaturated portion of the root zone by capillary action. This process makes it difficult to determine the amount of water contained in the root zone that will be available for vine use.

## C. Measuring Water Sources

### *Soil Moisture Content and Tension*

A volume of soil contains solid particles-sand, silt, and clay-and voids or pores. The pores contain air and water. Void or pore volume, which contains air and water, ranges from about 30 percent in sand to about 50 percent in clay of the total volume of soil. Clay has more pore volume than sand, but the pores are smaller because of the smaller particle sizes of clay. Sand has larger pore sizes because of larger particle sizes. Both pore volume and pore size play major roles in water movement and water retention or water-holding capacity of soil.

Saturated soil has pores completely filled with water. (In reality, complete saturation does not occur because some entrapped air exists in saturated soil.) No air can flow through the soil. Unsaturated soil has pores partially filled with water so that air can flow through the soil.

#### *Soil Moisture Content*

The amount of water in soil is the soil moisture content. Methods used to describe soil moisture content are gravimetric soil moisture content, volumetric soil moisture content, and depth of soil moisture per depth of soil. The section, *Soil Sampling*, contains detailed information on these descriptions. Both volumetric soil moisture content in percent and depth of soil moisture per depth of soil are most commonly used. Using gravimetric soil moisture content can underestimate the amount of soil moisture used or available by plants.

Gravity drainage and crop use of soil moisture drains water out of the pores after irrigation. This causes a saturated soil to become unsaturated. The largest pores empty first followed by progressively smaller pores as drainage continues. Thus, the remaining soil moisture occupies the smaller pores, and as drainage continues, the moisture is retained in progressively smaller pores.

#### *Soil Moisture Tension*

The retained soil moisture is held in the soil by a complex phenomenon called surface tension. Surface tension generates a force that binds the water to the soil particles. The magnitude of the force depends on soil moisture content. The drier the soil, the larger the surface tension forces, and the larger the tenacity at which water is held in soil.

The soil moisture tension is a measure of the tenacity at which water is retained in soil. As soil dries, soil moisture tension increases, and the more the energy needed to extract soil moisture. Other terms used to describe this tenacity are soil suction, matric potential, matric suction, or soil water suction. Units commonly used for soil moisture tension are bars and centibars (1 bar = 100 centibars). Most tensiometers and electrical resistance blocks used for irrigation scheduling use centibars as the unit of measurement.

**Soil Moisture  
Release Curves**

The relationship between soil moisture content and soil moisture tension depends on soil texture. For a given soil moisture tension, soil moisture content of a sandy loam will be less than that of clay loam. The relationship between soil moisture tension and soil moisture content is described by soil moisture release curves, shown in *Figure C-2* for various soil textures. Other terms used for these curves are water holding characteristic curves, water retention curves, and water release curves.

*Figure C-1* shows generalized soil moisture release curves for several soil textures. Sandy soil has the smallest amount of retained water for a given tension, and the clay soil the largest. From the figure, we see that as soil moisture tension increases, soil moisture content of sandy soil rapidly decreases, whereas the decrease is more gradual for loam soil. Thus, small changes in soil moisture tension result in large changes in soil moisture content for sandy soil, whereas, small moisture changes occur for a clay loam soil.

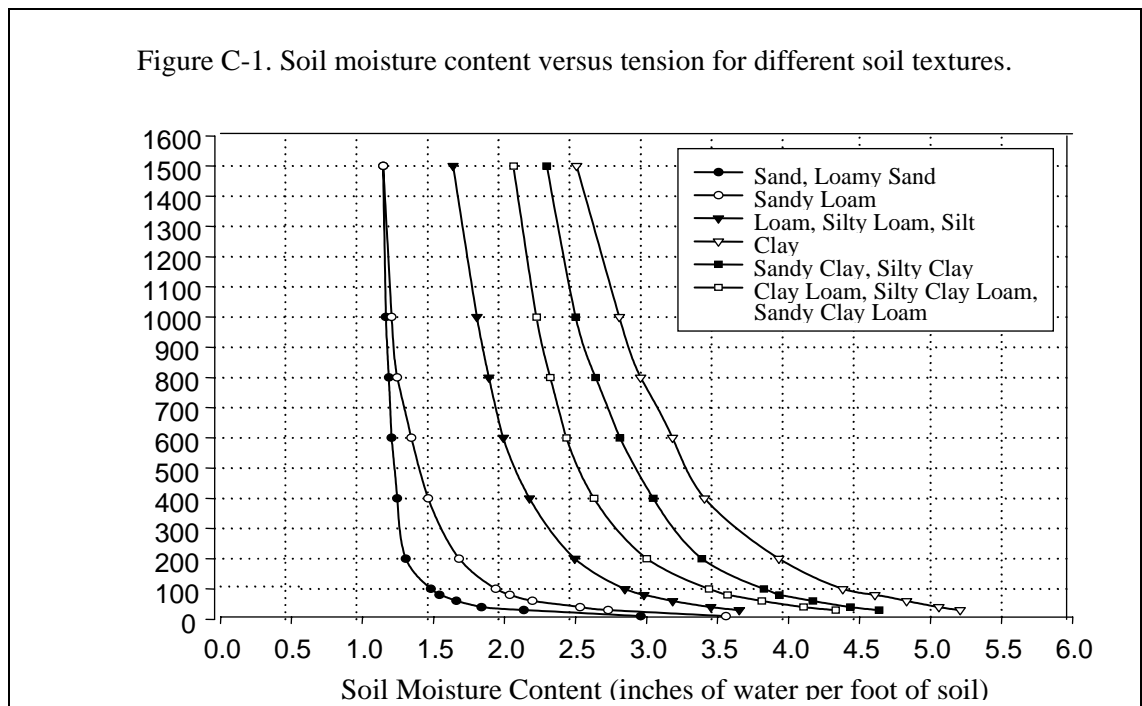

(Source: Ley, T., R. G. Stevens, R. R. Topielec, and W. H. Neibling. 1996. *Soil water monitoring and measurement*. PNW475.)

## Available Soil Moisture

### Available Soil Moisture

Available soil moisture is moisture that plants can use. It depends on soil texture. The upper limit of available soil moisture is the field capacity, defined as the soil moisture at which drainage ceases. Field capacity occurs at soil moisture tensions of 1/10 bar (10 centibars) for sandy soil and 1/33 bar (33 centibars) for other soil. The lower limit is the wilting point, defined as the soil moisture at which plants wilt permanently. Permanent wilting point occurs at 15 bars of soil moisture tension. Sandy soils have less available soil moisture than clay soils. *Tables C-1 and C-2* list average values and ranges of available soil moisture for various soil textures.

Total available soil moisture in the root zone is available soil moisture obtained from *Table C-1* multiplied by root depth.

<i>Table C-1. Soil moisture content in inches of water per foot of soil at field capacity, 15 bars, and available soil moisture for various soil textures.</i>			
Soil Texture	Field Capacity	15 Bars	Available Moisture Content
Sand	1.2	0.5	0.7
Loamy Sand	1.9	0.8	1.1
Sandy Loam	2.5	1.1	1.4
Loam	3.2	1.4	1.8
Silt Loam	3.6	1.8	1.8
Sandy Clay Loam	3.5	2.2	1.3
Sandy Clay	3.4	1.8	1.6
Clay Loam	3.8	2.2	1.6
Silty Clay Loam	4.3	2.4	1.9
Silty Clay	4.8	2.4	2.4
Clay	4.8	2.6	2.2

Sometimes soil moisture content is expressed as percent of water in a volume of soil, listed in *Table C-2*. For example, a moisture content of 32 percent means that 32 percent of the soil volume is water. To convert from percent soil moisture content to inches of water per foot of soil, multiply percent content by 12 inches per foot and divide by 100. For example, 32 percent soil moisture content x 12 inches per foot / 100 = 3.8 inches of water per foot of soil.

<i>Table C-2. Volumetric (%) soil moisture content at field capacity, 15 bar, and available soil moisture for various soil textures</i>			
Soil Texture	Field Capacity (%)	15 bar (%)	Available Moisture Content (%)
Sand	10	4	6
Loamy Sand	16	7	9
Sandy Loam	21	9	12
Loam	27	12	15
Silt Loam	30	15	15
Silty Clay Loam	36	20	16
Clay Loam	32	18	14
Sandy Clay Loam	29	18	11
Sandy Clay	28	15	13
Silty Clay	40	20	20
Clay	40	22	18

Available moisture contained in the root zone, which will be extracted during the season, can be easily estimated using a quantitative moisture-measuring device. (See *Neutron Moisture Meters*) The amount of water contained in the root zone should be measured at bud break and again at the dry point, occurring at harvest for irrigated vineyards. The difference between these values equals the amount of water that typically is available for use during the period bud break through harvest. Figure C-2 shows the amount of available water measured in the same Lodi vineyard over an eight year period. For this use, it is best to locate the access well away from a drip emitter's wetted area. It is necessary to measure the bud break soil water content each year since the amount of effective rainfall varies each year as well as residual post harvest irrigation amounts.

The amount of water remaining in the root zone is influenced by the irrigation strategy and any changes in the root zone over time by further root extensiveness. A deficit irrigation strategy results in a relatively dry root zone at harvest and works well in this scenario. However, a full irrigation regime will at harvest contain substantial quantities of water in the root zone with its distribution depending on the irrigation schedule and distribution of the irrigation water.

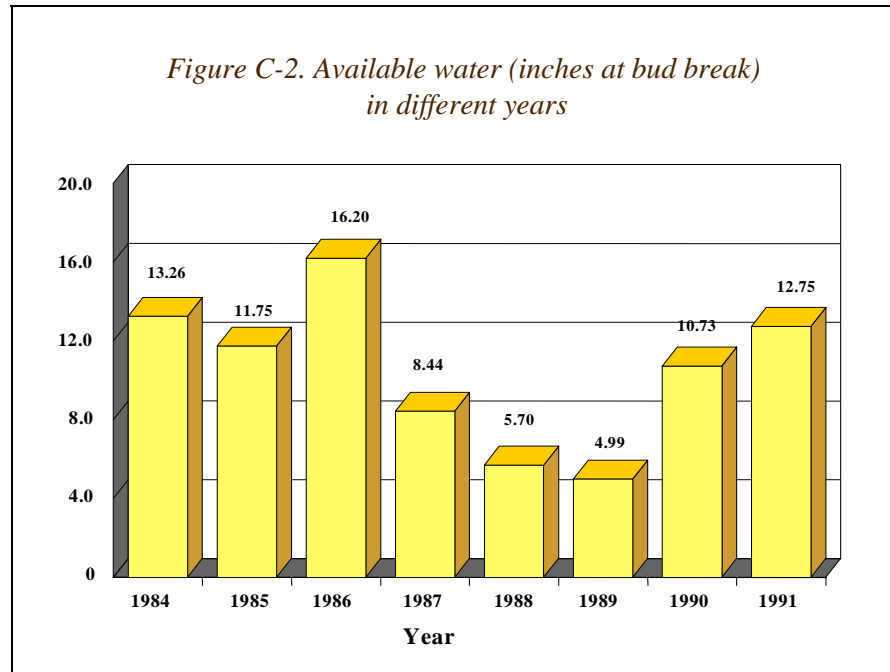

General References.

Ratliff, L. F., J. T. Ritchie, and D. K. Cassel. 1983. "Field-measured limits of soil water availability as related to laboratory-measured properties." *Soil Science Society of America Journal*, Vol. 47:770-775.

## ***Measuring Soil Moisture***

Many methods exist for measuring or monitoring soil moisture content. Methods that measure soil moisture content help determine when to irrigate and how much soil moisture was used. Methods that measure soil moisture tension help determine when to irrigate, but they require calibration to relate soil moisture tension to soil moisture content. Even though reliable calibrations may be unavailable, monitoring soil moisture tension provides useful information on trends of soil moisture content with time, patterns of soil moisture uptake by roots, and depths of wetting. In addition, simple observations correlating soil moisture content determined by soil sampling and the instrument's reading could help to determine those readings that indicate a need to irrigate.

These methods and their use, described in detail in the succeeding sections, are summarized as follows.

***Methods***

Soil probe/soil sampling. Soil samples are obtained using a soil probe or auger. Appearance and feel of the soil is related to soil moisture using an appropriate chart. Soil samples can also be dried in an oven to determine actual soil moisture.

Tensiometers. A tensiometer is a plastic tube with a porous cup attached to one end and a vacuum gauge attached to the other end. The porous cup is inserted into the soil, and the vacuum gauge

measures the soil moisture tension. Tensiometers measure soil moisture tension. See “Tensiometers.”

Electrical resistance blocks. These devices are two electrodes embedded in gypsum or a gypsum-ceramic mixture. Changes in soil moisture content cause changes in the water content of the block, which in turn changes its electrical resistance. An appropriate instrument is used to read the electrical resistance or conductance of the block depending on the manufacturer. Readings of resistance blocks are related to soil moisture tension. See “Electrical Resistance Blocks.”

Neutron moisture meters or neutron probes. This method involves lowering a tube containing a sealed radioactive source and a detector into the soil. Fast neutrons are emitted by the radioactive source and then are converted to slow neutrons by hydrogen atoms in the soil water. The amount of slow neutrons is related to soil moisture content. This instrument measures soil moisture content over a volume of soil with a horizontal diameter of about 12 inches and a vertical diameter of about 6 inches. See “Neutron Moisture Meters.”

Dielectric Soil Moisture Sensors. Dielectric moisture instruments measure the dielectric constant of the soil. This constant, an electrical property of the soil, depends on soil moisture content. Appropriate calibration equations relate dielectric constant to soil moisture content. A variety of instruments are available. See “Dielectric Soil Moisture Sensors.”

***Which method is the best?***

No one method is the best. Each has advantages and disadvantages depending on the use of the measurement. Since the implementation of deficit irrigation strategies requires a quantitative measurement of soil moisture for use in the calculation of applied water volumes, neutron meters or dielectric sensors are preferred. Tensiometers, electrical resistance blocks, and the soil probe feel method however useful for soil moisture status are not appropriate for this use.

## ***Soil Sampling***

Soil sampling is commonly used to determine soil moisture content. Two types of soil sampling are gravimetric sampling and volumetric soil sampling.

***Gravimetric Soil Moisture***

Gravimetric sampling measures soil moisture content on a weight basis by dividing the weight of water in the sample by the dry weight of the soil sample. An auger for obtaining soil samples, an oven for drying the soil, and a balance or scale for weighing the samples before and after drying are needed.

***Volumetric Soil Moisture***

Volumetric sampling measures the soil moisture content on a volume basis by dividing the weight of water in the sample by the volume of the sample. A soil sampler that collects a sample of a known volume, an oven, and a balance are required.

***Procedure***

Soil samples are collected at the desired locations, and then are weighed and dried to determine their moisture content. A step-by-step procedure follows:

1. Collect a soil sample at the desired location and depth. This may require auguring or excavating to reach the required depth. Any one of a number of commercially available samplers or augers can be used. A volumetric soil sampler is required for measuring the volumetric soil moisture.

2. Remove the sample from the collection device, place it in a metal container of known weight, and then weigh the sample and container. If the sample cannot be weighed immediately, the can should be sealed tightly for later weighing.
3. After the weight of the can and wet soil sample has been measured, place the opened can containing the soil sample in an oven. Dry the sample for at least 24 hours (preferably 48 hours) at a constant temperature of 105°C (221°F).
4. When drying is completed, allow the can to cool, and then weigh the can and the dry soil sample. The weight decrease is the amount of soil moisture in the soil sample at the time it was collected.
5. Use the following formulas to calculate the moisture content and the bulk density of the sample.

[1] Gravimetric soil moisture (GM)

$$GM = (W_w - W_d) / W_d$$

$W_w$  = weight of the wet soil

$W_d$  = weight of the dry soil (weight of can must be subtracted from weight of dry soil + can)

[2] Volumetric soil moisture (VM)

$$VM = V_w / V_s = (W_w - W_d) / V_s$$

$V_w$  = volume of water in the sample

$V_s$  = volume of the soil sample.

$V_w$  equals  $W_w - W_d$  where the weight is in grams. Units of measurement must be consistent for calculating the volumetric soil moisture. No conversion is needed for weight expressed in grams and volume expressed in cubic centimeters or milliliters because 1 cubic centimeter of water weighs 1 gram. If the weight is in ounces and the volume is in cubic inches, then divide the weight by 0.578 to calculate the cubic inches of water in the sample.

The depth of water per depth of soil can be determined from the volumetric soil moisture content. Multiply the volumetric water content expressed as a decimal fraction by the depth interval over which the sample was collected to calculate the depth of soil moisture over that depth interval. For example, if the depth interval is 12 inches, multiply the volumetric water content by 12 to calculate the inches of water per foot of soil.

- [3] Soil bulk density (BD). The soil bulk density of the soil is necessary to convert gravimetric soil moisture to a depth of water. The bulk density (BD) is as follows.

$$BD = W_d / V_s$$

*Which is the best?*

Gravimetric moisture content is multiplied by bulk density to obtain volumetric moisture content.

Gravimetric sampling is the easiest because measuring the volume of the soil sample is not necessary. However, crop water use is expressed as a depth of water. This means that the volumetric moisture content must be used to estimate crop water use. For a given soil sample, the volumetric soil moisture content will be greater than the gravimetric soil moisture content.

*Soil Probes and Augers*

Soil probes and augers can be purchased from the following:

Art's Manufacturing & Supply  
105 Harrison  
American Falls, ID 83211  
Telephone: (800) 635-7330  
Fax: (208) 226-7280

Ben Meadows Company  
2589 Broad Street  
Atlanta, Georgia 30341  
Telephone: (800) 241-6401  
Fax: (800) 628-2068

## Tensiometers

### What is a tensiometer?

A tensiometer—a device for measuring soil moisture tension—is a cylindrical pipe about one inch in diameter with a porous ceramic cup attached to one end and a vacuum gauge attached to the other (*Figure C-3*). The porous cup allows water to flow in and out of the tensiometer as soil moisture content changes. The vacuum gauge readings, which measure soil moisture tension, change in response to this water flow. Units of gauge readings for commercially made tensiometers frequently are in centibars, with the vacuum gauge ranging between 0 and 100 centibars. A reservoir is located at the top of the tensiometer. The tensiometer must be sealed tightly to prevent air from entering to operate properly.

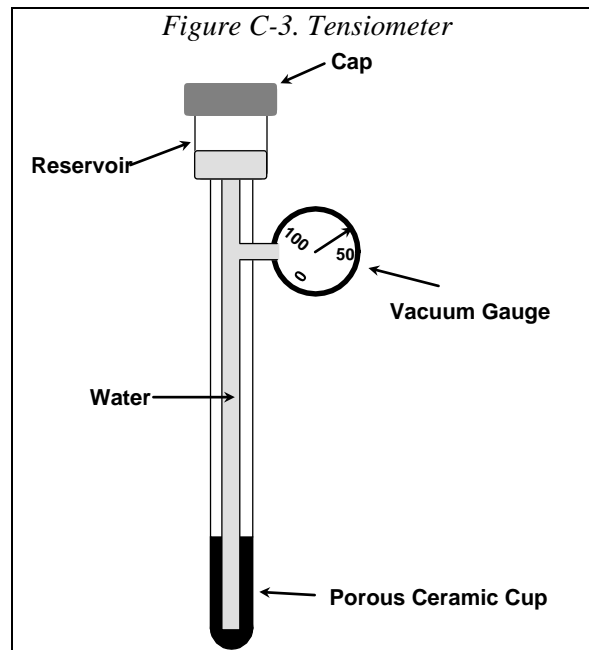

Tensiometers are easy to install, read, and maintain. They provide information on soil moisture tension, which helps irrigators determine when to irrigate.

Tensiometers do not directly measure soil moisture content. Relationships between tensiometer readings and soil moisture contents are needed to determine soil moisture depletions. These relationships depend strongly on soil texture, as shown in *Figure C-4* for sandy loam and silt clay. While generalized relationships exist for various soil textures, their accuracy is uncertain for any given site. Calibration for a particular site requires sending soil samples to a laboratory to develop a soil moisture release curve.

Figure C-4. Tensiometer reading versus soil moisture content for two soil textures.

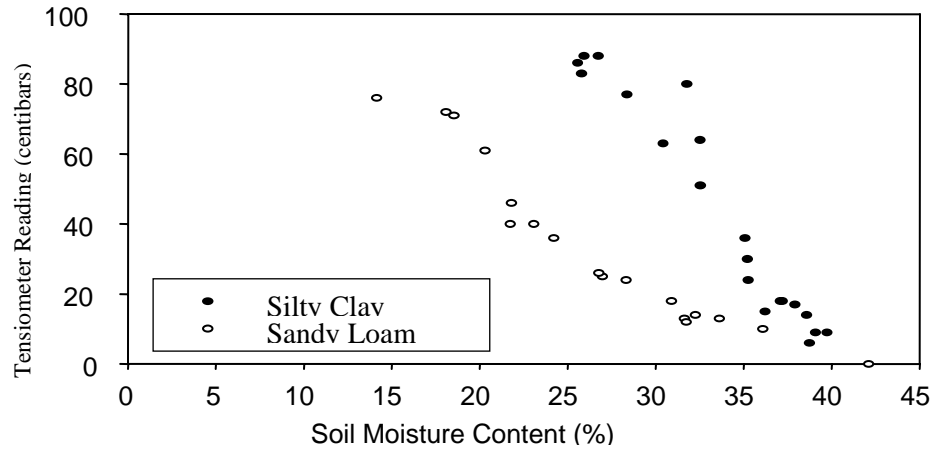

**How does a tensiometer operate?**

As soil dries, soil moisture content decreases and soil moisture tension increases. This decrease in soil moisture content causes water to flow out of the tensiometer through the porous cup, and the tensiometer gauge to read higher and higher. During irrigation, soil moisture content increases causing soil moisture tension to decrease and water to flow into the tensiometer. This causes tensiometer readings to decrease.

Water flows in and out of tensiometers only if the porous cup is saturated with water. If the cup de-saturates, then little or no flow occurs, and air enters the tensiometer. The tensiometer then stops operating.

Figure C-5 shows tensiometer readings with time in drying soil. Initially, the tensiometer reading increases with time. Eventually, readings become constant with time, even though drying continues, because the vapor pressure of water is reached, about 80 centibars at sea level. At that vacuum, water turns into vapor preventing any further increases in tensiometer readings. As soil continues to dry, tensiometer readings drop to zero because the porous cup de-saturates and allows air to enter the tensiometer.

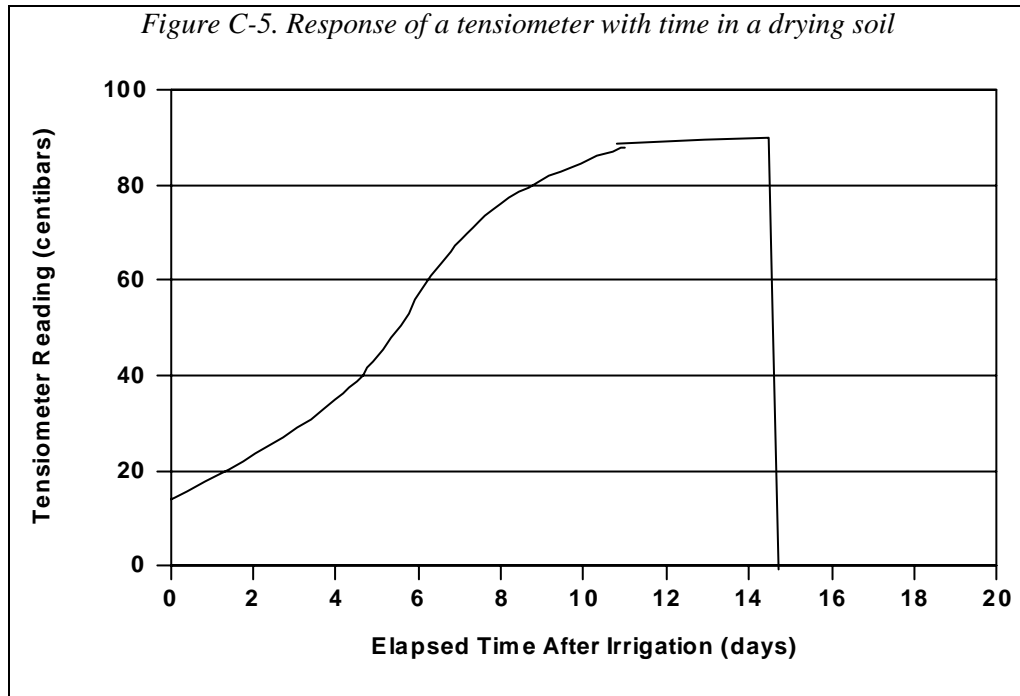

To restore proper operation, tensiometers must be re-saturated by filling the pipe and reservoir with water and flowing water through the porous cup for several hours before sealing the pipe. However, unless the soil is rewetted by an irrigation, the porous cup will rapidly de-saturate again. Thus, tensiometer readings that drop to zero in dry soil do not necessarily indicate faulty instruments, but rather dry soil with moisture contents likely to reduce crop growth and yield of water-stress sensitive crops.

**Maximum Readings**

Because of the vapor pressure of water, maximum tensiometer readings at sea level are 80-85 centibars. Maximum readings decrease with altitude because vapor pressure depends on altitude. At 3,000 feet, about 60 centibars is maximum for tensiometers.

**Problems in Sandy Soil**

A tensiometer may operate poorly in a very sandy soil. The coarseness of the sand may cause poor hydraulic contact between the porous cup and the soil. Thus, water will not readily flow in and out of the tensiometer resulting in a very slow response of the tensiometer to changes in soil moisture. One manufacturer markets a tensiometer that is designed to overcome this problem to some degree by using a relatively coarse porous cup.

**Installing a Tensiometer**

First, soak the tensiometer in water for several hours to saturate the porous cup. Next, make a pilot hole with a soil probe down to the desired depth. Pour a small amount of slurry of soil and water into the pilot hole before inserting the tensiometer to ensure good hydraulic contact between soil and porous cup. Next, insert the end of the tensiometer with the porous cup into the pilot hole. Then fill the tensiometer with water, seal it, and allow it to equilibrate for about 24 hours before making readings.

Install tensiometers at about one-fourth to one-third of the maximum root depth to schedule irrigations. Another tensiometer installed near the bottom of the root zone is recommended to monitor depth of wetting. Tensiometer readings at that depth that do not change after irrigation or continue to increase during the growing season indicate insufficient water applications.

### ***Adjusting Tensiometer Readings***

The number of tensiometer stations required depends on irrigation system type, soil uniformity, and cropping patterns. At least two stations should be established for every 40 acres. More stations may be needed depending on soil texture variability. In fields with different crops, monitor each crop separately because of different water use patterns.

Tensiometer readings will differ from the actual soil moisture tension (SMT) because of the tensiometer's length between porous cup and vacuum gauge. Some instruments can be adjusted for this length by filling them with water, standing them upright in a pan containing enough water to cover the cup, and adjusting the gauge. Otherwise, tensiometer readings are adjusted by the following equation.

$$SMT(\text{centibars}) = \text{Tensiometer Reading}(\text{centibars}) + \text{Length}(\text{inches}) \div 4$$

Periodic maintenance is required for tensiometers. Periodically fill the tensiometer with water and replace porous cups and O-rings as needed. A cracked cup prevents a vacuum from occurring in the tensiometer causing the instrument to always read zero. A saturated porous cup should not be exposed to the atmosphere for long periods of time. Such exposure evaporates water from the cup's surface causing salt buildup and clogging. Copper sulfate or an algacide may be needed to prevent algae growth in the tensiometer.

### ***Maintenance***

### ***Automation***

Tensiometers can be used with automated irrigation systems. Soil moisture tension is measured with pressure transducers in addition to vacuum gauges. Solenoids attached to the instrument then turn water on and off based on soil moisture tensions measured by transducers.

### ***Where can I purchase tensiometers?***

Tensiometers are available through local irrigation equipment dealers. They come in standard sizes ranging from 6 to 72 inches. Manufacturers who supply tensiometers include:

Irrrometer Co., Inc.  
P.O. Box 2424  
Riverside, CA 92516-2424  
Telephone: (909) 689-1701

Soil Moisture Equipment Corp.  
P.O. Box 30025  
Santa Barbara, CA 93105  
Telephone: (805) 964-3525

## Electrical Resistance Blocks

### What is an electrical resistance block

Electrical resistance blocks, commonly called gypsum blocks or soil moisture blocks, measure the electrical resistance of the blocks' moisture content. This device uses two electrodes embedded in gypsum or a granular material (see *Figure C-6*). Wires extending to the soil surface connect the meter to the blocks.

Electrical resistance blocks are easy to install, read, and maintain. Because they are buried, damage by farming equipment, animals, etc. is minimal.

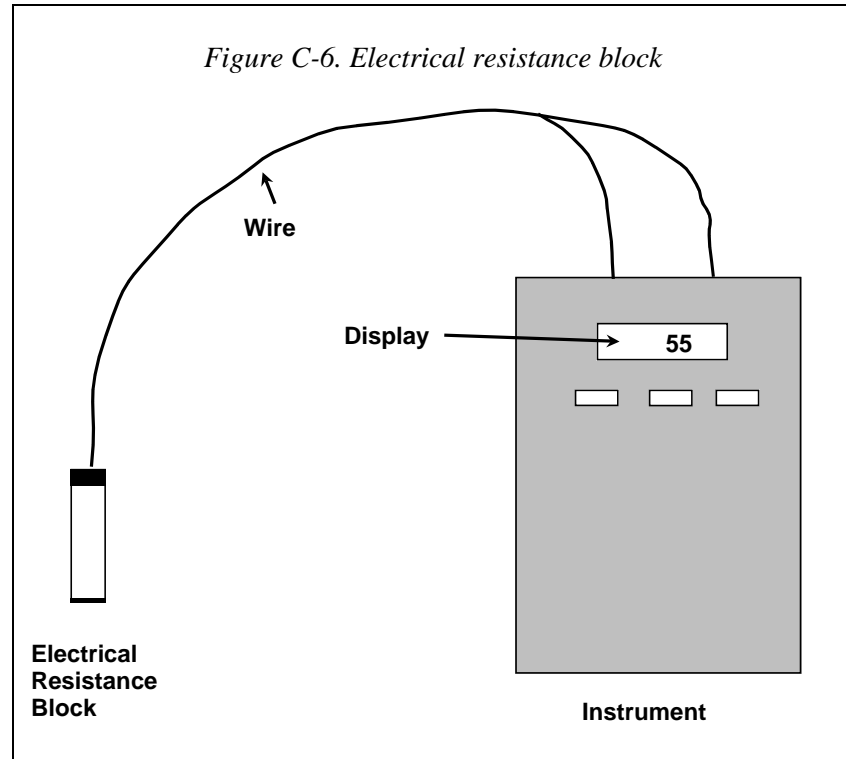

### Types of Blocks

Most electrical resistance blocks are made of gypsum. Gypsum stabilizes the salinity of the moisture in the block, thus buffering the effect of salinity on electrical resistance or conductance.

The granular matrix sensor marketed as the Watermark block contains electrodes embedded in a ceramic-sand material. A wafer of gypsum installed in the granular material buffers salinity effects on the readings. The instrument provided for these blocks reads in centibars of soil moisture tension.

### How do resistance blocks operate?

Drying soil causes water to flow out of the resistance block. Its electrical resistance is then increased because the conducting area for electrical current is reduced. This is analogous to increasing the electrical resistance between two electrodes attached to a wire by using a smaller and smaller wire. Rewetting the soil causes soil water to flow into the block, thus, increasing the conducting area and decreasing its electrical resistance.

Electrical resistance of blocks also depends on the salinity of the block water. Salinity effects are stabilized by the gypsum in the block dissolving or precipitating as the block water content changes. These reactions maintain a constant electrical conductivity of the block water. However, if the salinity of the soil moisture exceeds that of a saturated gypsum solution, block salinity can increase and affect the electrical resistivity of the block. Soil salinity can affect readings of resistance blocks if the electrical conductivity of saturated extracts of soil samples exceeds about 1 to 1.5 dS/m (mmhos/cm).

***Response to  
Changes in Soil  
Moisture***

*Figure C-7* shows responses of gypsum block readings to changes in soil moisture content for two soil textures. Block readings in sandy loam changed little for soil moisture contents greater than about 25 percent. Large changes occurred for smaller moisture contents. In silty clay, readings changed considerably for moisture contents smaller than about 40 percent. These behaviors show gypsum block readings not responding to changes in soil moisture content for moisture contents greater than some threshold value. This value depends on soil texture, with larger threshold values for fine-texture soil than for coarse-texture soil.

The response of the Watermark block for two soil textures, in *Figure C-8*, showed much more sensitivity to changes in soil moisture content in wet soil. Block readings increased gradually as soil moisture content decreased. This response reflects a wider range of pore sizes in the block material compared with the gypsum block. These devices operate over a wider range of soil moisture tensions than do tensiometers.

These results show that some resistance blocks may be insensitive to changes in soil moisture in wet soil. These blocks are more appropriate for use under low-frequency irrigation methods. Watermark blocks are more responsive to changes in moisture content, making them suitable for both low-frequency systems and micro-irrigation systems where frequent irrigations keep soil relatively wet.

***Installing  
Electrical  
Resistance Blocks***

First, soak blocks in water for a few minutes to saturate them. Then, make a small-diameter hole with a soil probe or a small-diameter auger to a depth slightly deeper than that desired. Next, add slurry consisting of water, a small amount of soil, and, if possible, gypsum to the hole to provide good contact between soil and block. Before installing a block, check the block reading to ensure that the block is working.

Figure C-7. Response of a gypsum block to soil moisture content.

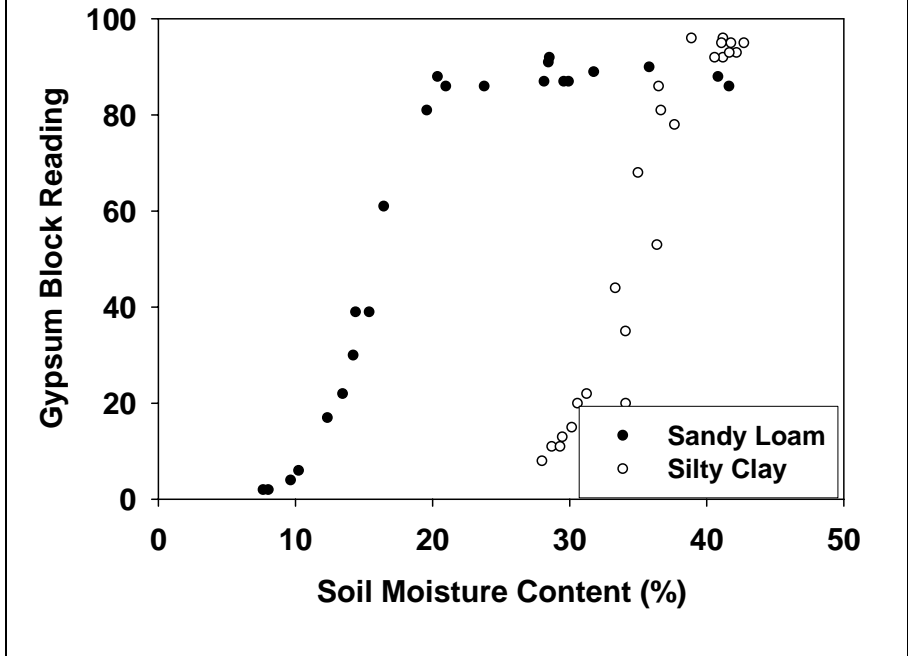
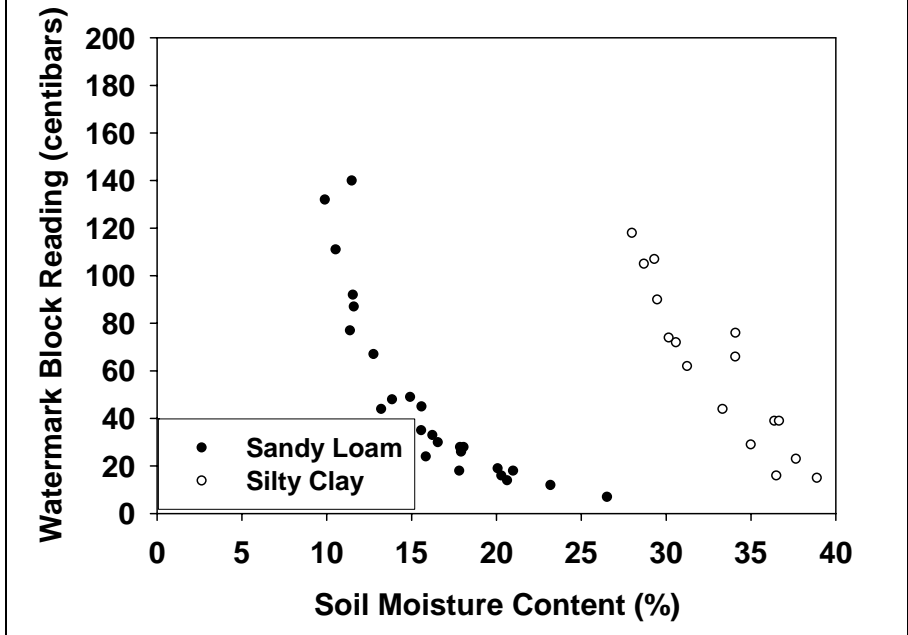

Figure C-8. Response of a granular matrix block to soil moisture content



Push the block into the slurry in the bottom of the hole with a length of PVC pipe (1/2", Schedule 80). Remove the pipe and backfill the hole with soil removed from the hole. Do not damage the wire leads during the backfilling. As the hole is filled, pack the backfilled soil in the hole with the PVC pipe. Be sure to identify each block with a tag or knots in the wire.

As a minimum, install one block at approximately one-fourth to one-third of the root zone to schedule irrigations and a block at the bottom of the root zone to monitor depth of wetting. Blocks installed at one-foot depth intervals, however, provide better information on depth of wetting and soil moisture uptake patterns. Little change in block readings at the lower depths after irrigation indicates insufficient water applications.

Install at least two sites of blocks for every 40 acres. More sites may be needed depending on soil texture variability. Separate stations for problem areas or for areas having different soil conditions are recommended.

Watermark blocks are read in a similar manner, as is a tensiometer.

***What do readings mean?***

For other resistance blocks, instrument readings must be correlated with soil moisture contents or soil moisture tensions to establish relationships between readings and need to irrigate. Even if no correlation exists, however, resistance blocks can help identify patterns of moisture uptake, depths of wetting, and trends of the soil moisture content with time.

***Response in Sandy Soil***

In very coarse-textured soils, the response of electrical resistance blocks may lag behind changes in soil moisture content caused by poor hydraulic contact between blocks and soil. Under these conditions, block readings may indicate little depletion of soil moisture even though severe drying of soil may occur.

***Temperature Effects***

The reading of an electrical resistance block also depends on the temperature of the soil. The electrical resistance decreases as the temperature increases. One manufacturer provides for adjustments for temperature while others do not.

***Can an ohm meter be used?***

A question frequently asked is, "Can an ohm meter be used instead of the manufacturer's meter?" The answer is no. Ohmmeters use DC voltage. Applying DC power to resistance blocks causes polarization at the electrodes and results in unstable readings. The manufacturers' meters convert DC to AC, which stabilizes the meter readings.

***Maintenance and Block Life***

Resistance blocks are relatively maintenance-free. Gypsum blocks may last one to three years, depending on soil moisture conditions. Constantly wet soil causes gypsum blocks to dissolve more quickly, thus shortening their lives. As gypsum dissolves, contact between block and soil may be lost. Longer life can be expected for blocks made of porous materials that do not dissolve. The wire leads may corrode and require occasional scraping to ensure good contact between wire and meter.

The cost of resistance blocks range from about \$6 to \$20 depending on the manufacturer. The meter used to read all blocks may range in cost from \$200 to \$400. Manufacturers of resistance blocks and meters include:

**Costs and Suppliers**

Irrrometer Company, Inc.  
(Watermark Block)  
P.O. Box 2424  
Riverside, CA 92516  
Telephone: (909) 689-1701

Soil Moisture Equipment Corp.  
P.O. Box 30025  
Santa Barbara, CA 93105  
Telephone: (805) 964-3525

Electronics Unlimited  
3231 Riverside Blvd.  
Sacramento, CA 95818  
Telephone: (916) 448-2650

Delmhorst Instrument Company  
51 Indian Lane East  
Towaco, NJ 07082  
Telephone: (201) 334-2557

**Neutron Moisture Meters**

**What is a neutron moisture meter?**

Neutron soil moisture meters (neutron probe) use radioactive material for measuring soil moisture. They contain an electronic gauge, a connecting cable, and a source tube containing both nuclear source and detector tube (Figure C-9). An access tube is installed in the ground, and the source tube is lowered into the tube to the desired depths of measurement.

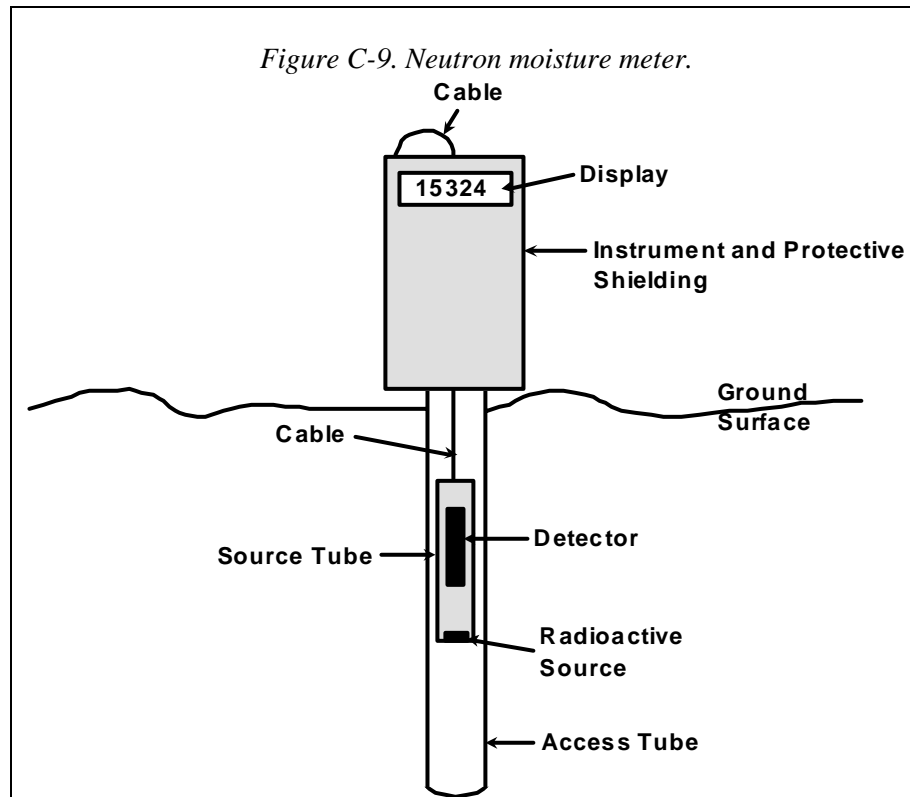

An Americium 241/Beryllium pellet emits high-energy neutrons. Lowering the source tube down in soil causes high-speed neutrons to collide with hydrogen atoms in water and soil. Their energy is then lost and low-energy or “slow” neutrons are created. Some slow

neutrons are reflected back to the source tube and counted by the neutron detector. These “counts” are transmitted to the gauge and displayed. Because soil moisture is the primary source of hydrogen atoms, neutron moisture meters indirectly measure soil moisture content.

An advantage of these meters is a volume of soil about the size of a volleyball is sampled. This more reflects soil moisture contents affecting plant growth compared with sampling volumes of other moisture sensors. Another advantage is that same depths can be measured each time. Measurements can be made at a given site in a few minutes.

One disadvantage of this device is that reliable measurements at shallow depths (less than six inches) may not be possible because some neutrons escape from the soil surface into the air instead of being detected. The main disadvantage of this method, however, is that because a nuclear source is used, operators must be trained in its handling, storage, and use. Licensing is also required with periodic inspections.

### ***Installing a Neutron Moisture Meter***

First, install an access tube to the desired depth. Aluminum pipe, PVC pipe, or electrical metal tubing (EMT) is commonly used for access tubes. Because meter readings are affected by access tubing material, the same material must be used for each site. Aluminum affects the readings the least, while PVC affects the readings the most because “slow neutrons” are absorbed by chlorine in PVC. Pipe 2 inches in diameter is commonly used. In high water table areas, the bottom of the access tubing must be sealed to keep out water. Water in the access tube can damage the source tube and cause very high readings.

Auger a hole about the same diameter as the outside diameter of the access tubing to a depth of about 6 inches deeper than that desired for the readings. A small gap between access tube and soil can be tolerated, but surface water should not flow down the side of the access tube. Cover the top of the access tube between measurements to keep water, frogs, and other foreign material out of the tube.

### ***Calibrating the Neutron Moisture Meter***

Calibrate neutron moisture meters for soil type for best results. A “universal” calibration curve is available for each instrument, but calibration curves can differ for various soil types. The calibration procedure is somewhat complex and should be done by someone who is familiar with the procedure and has the proper equipment.

The calibration curve relates count ratio (or actual count) to soil moisture content (see *Figure C-10*). The count ratio is the actual count divided by a standard count. The standard count is made with the source tube locked in the meter. Count ratios are recommended because actual counts can change with time due to deterioration of the radioactive source and electronic drift of the instrument.

A procedure for developing a calibration curve is:

1. Take volumetric soil samples at each measurement depth. Gravimetric sampling is not recommended. (See “Soil Sampling” for detailed information on sampling.)
2. Take readings with the neutron meter at each measurement depth. A standard count should also be made.
3. Measure the volumetric soil moisture content of the soil samples.

Figure C-10. Count ratio to soil moisture content.

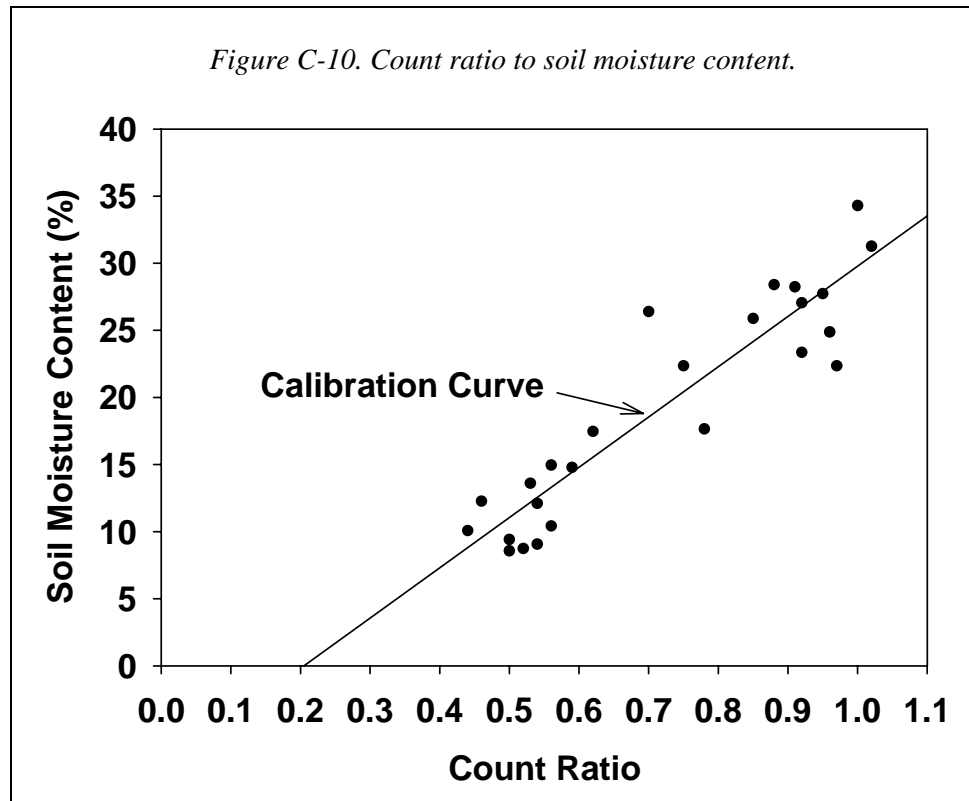

4. The equation for relating the count ratio to the soil moisture content is as follows.

$$SM = a + (b)(CR)$$

where: SM = volumetric soil moisture content  
CR = count ratio  
a = y-intercept of the calibration equation  
b = slope of the calibration equation

A hand calculator or computer spreadsheet software with a linear-regression program can be used to calculate the constants “a” and “b”. Otherwise, plot the data on graph paper and draw a best-fit line through the data points. Determine the y-intercept and the slope of the drawn best-fit line.

### Placement of Monitoring Sites

At least two sites for each 40 acres are recommended. More sites may be necessary depending on soil variability. Additional sites may be needed for problem areas or for areas with different soil or management conditions.

The maximum depth of access tubes should be at least the depth of the root zone. However, measuring moisture contents at deep depths may be desirable for monitoring percolation below the root zone.

Access tubes can be placed in different locations depending on the purpose of the reading. If measuring the depth of irrigation water penetration, placement under the dripper or in the wetted area of a micro-sprinkler is best. For determining water extraction before irrigation begins, a berm placement 25 percent of the distance between vines on the berm is typical. This practice works well with deficit irrigation since the entire soil becomes quite dry before irrigation begins. For full potential irrigation or for young vines, several access tubes in the wetted zone may be needed. If determining available water content, by measuring soil moisture content at bud break and at harvest (dry point) placement in the root zone and away from the emitter gives a more reliable reading.

***What do the readings mean?***

Actual counts are not very useful. Actual counts must be related to volumetric soil moisture contents expressed in inches of water per foot of soil using an appropriate calibration curve. Then, measured soil moisture contents can be compared with soil moisture contents at field capacity, and soil moisture depletion determined. Actual depletions can be compared with allowable depletions to determine when to irrigate and how much to apply.

Neutron meters can store multiple calibration curves in memory and can provide direct readouts of soil moisture content in a variety of terms, such as inches per foot and soil moisture percentage. Field readings can be stored for later retrieval or transfer to computers.

***Maintenance***

Neutron meters require little maintenance beyond checking to ensure proper operation. Access tubes should be checked for water or foreign materials in them. The most common failure is a broken or worn cable, which connects the source tube to the electronic readout device. Replacing cables will cost about \$120 every two years. However, in the event that the access tube contains water, considerable damage can occur if the source tube is submerged. Repair costs could exceed \$700. A repaired instrument may also require recalibration. Operator recertification is required every two years.

***Considerations in Using Neutron Moisture Meters***

Some considerations in using neutron moisture meters are:

1. Access tubing material can affect counting rates. Highest counting rates occur in aluminum, lowest in PVC.
2. A standard count is made periodically to monitor performance of the meter and to calculate count ratios (actual count divided by standard count). When determining standard counts, place the instrument at least 2 feet above the soil surface and at least 2 feet from any material that can influence the count. At least five counts are recommended for calculating the average standard count to minimize errors in the count ratio.
3. A slight air gap between access tube and soil will not greatly affect count rate. However, prevent ponded water from flowing down the gap. Root density also might be affected by gaps.
4. Normally, one count per depth is sufficient for an error of one percent or less. At least two counts per depth should be made if counts are less than about 5,000 per 30 seconds of counting time.
5. A 30-second counting time is recommended for meters with standard counts less than about 15,000 per 30 seconds. A 15-second counting time is suggested for meters with much larger standard counts (25,000 to 30,000 per 30 seconds).
6. Use caution in interchanging neutron moisture meters. Meters with similar standard counts and their calibration curves can be interchanged as long as count ratios are

used which standardizes the meter's performance. Meters with very different standard counts should not be interchanged unless calibration curves for each instrument are available. Using standard counts may not standardize performances of very different meters.

7. Counts made six inches below the surface are affected by the soil-air interface. However, the slope of a calibration curve for the 6-inch depth is similar to the slope of the calibration curve for the deeper depths. Thus, calculating changes in soil moisture contents at the 6-inch depth are not greatly affected by the soil-air interface.

The current cost of a neutron probe is approximately \$5,000 to \$6,000. Suppliers include:

### **Manufacturers**

Troxler Electronic Laboratories, Inc.  
P.O. Box 12057  
Research Triangle Park, NC 27709  
Telephone: (919) 549-8661

Boart Longyear CPN  
2830 Howe Road  
Martinez, CA 94553  
Telephone: (415) 228-9770

## ***Dielectric Soil Moisture Sensors***

Dielectric soil moisture sensors determine the soil moisture by measuring the dielectric constant of the soil. This constant is a measure of the ability of a dielectric material to establish an electrical field and is highly dependent on the soil moisture. The constant of a dry soil is between 3 and 5, about one for air, and is about 80 for water. Thus, changes in the soil moisture content change the dielectric constant of the soil. Calibration equations have been developed that correlate the soil moisture content and the dielectric constant. The most common dielectric methods are capacitance sensors and time-domain-reflectometry (TDR) sensors although other types of dielectric sensors exist.

The capacitance sensor (*Figure C-11*) consists of two electrodes separated by a material called the dielectric, a material that does not readily conduct an electrical current. Normally, cylindrical-shaped electrodes are used. Inserting the sensor into the soil results in the soil becoming part of the dielectric. An oscillator applies a frequency between 50 and 150 Mhz to the electrodes, which, in turn, results in a resonant frequency, the magnitude of which depends on the dielectric constant of the soil. The larger the soil moisture content, the smaller the resonance frequency will be.

### **Capacitance Sensors**

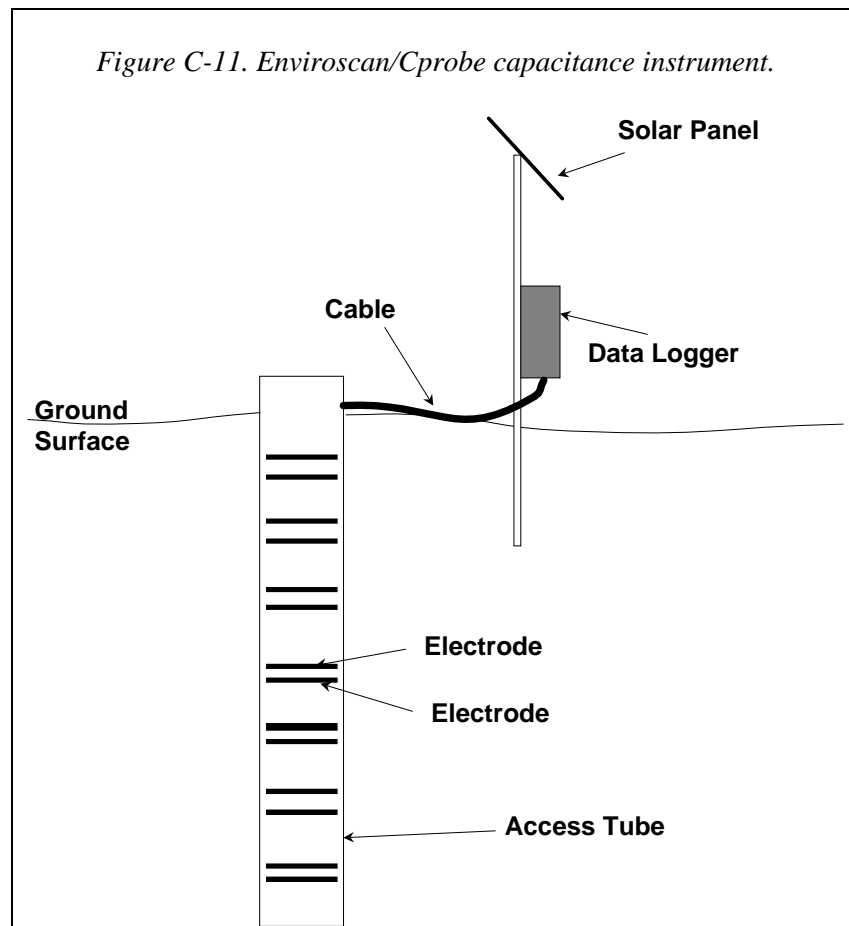

A calibration equation relating the dielectric constant and soil moisture content is necessary. Unfortunately, some uncertainty exists about the effect of soil texture and soil salinity on the calibration although the effect of soil salinity is thought to be small. Calibration equations may be necessary for different soil textures. Further research is needed on these topics.

The zone of influence of this sensor design is restricted to a narrow disk-shaped region surrounding the sensor and centered on the gap between the electrodes. Some uncertainty exists on the distance from the sensor over which the soil moisture content affects the sensor's reading. However, the sensor is most sensitive to the soil moisture content of the soil immediately adjacent to it. This sensitivity means that any air gap between the sensor and the soil will greatly affect the instrument's performance.

Advantages of capacitance probes include the ability to be left in place to continuously log soil moisture content; repeatability of measurements; sensitivity to small changes in soil moisture content; and their precise resolution with depth because of the narrow vertical zone of influence.

Disadvantages include the need for a calibration equation; the difficulty in developing the equation; the relatively small zone of influence; possible influence of soil salinity on

probe reading; and sensitivity to air gaps surrounding the sensor. Costs of these devices range from a few hundred dollars to many thousands of dollars.

**Time-Domain-Reflectometry**

Time-domain-reflectometry involves installing two or three steel rods, called waveguides, into the soil parallel to each other (*Figure C-12*). Components of a TDR system are a voltage pulse generator, a signal analyzer, the waveguides, and a cable connecting the waveguides to the instrumentation.

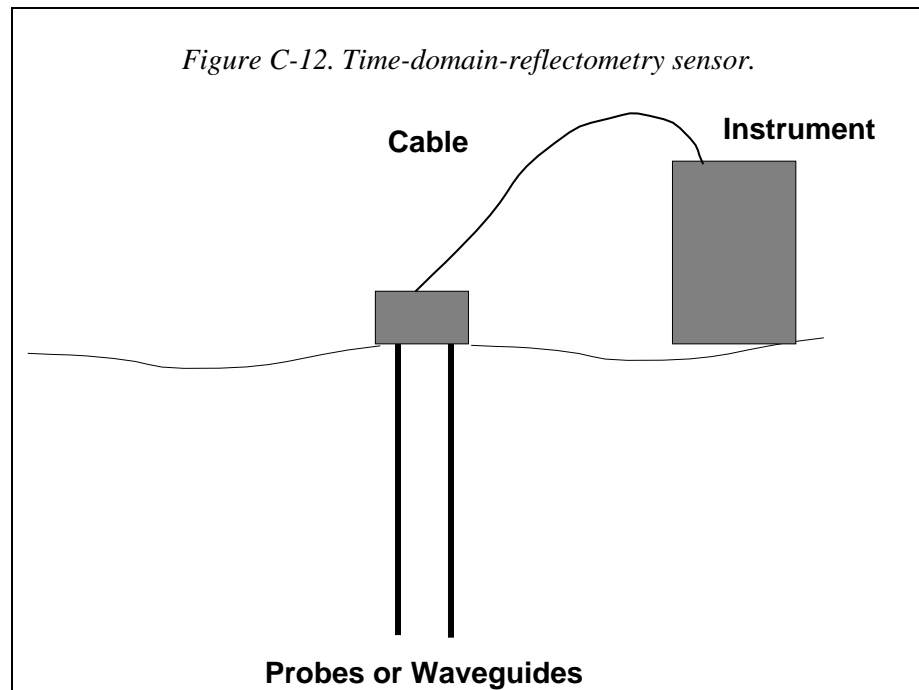

An electrical pulse applied to the waveguides travels its length, and then is reflected back as shown in *Figure C-13*. The travel time required for the pulse to reach the end of the waveguides and back depends on the dielectric constant of the soil. The larger the dielectric constant, the longer the pulse travel time.

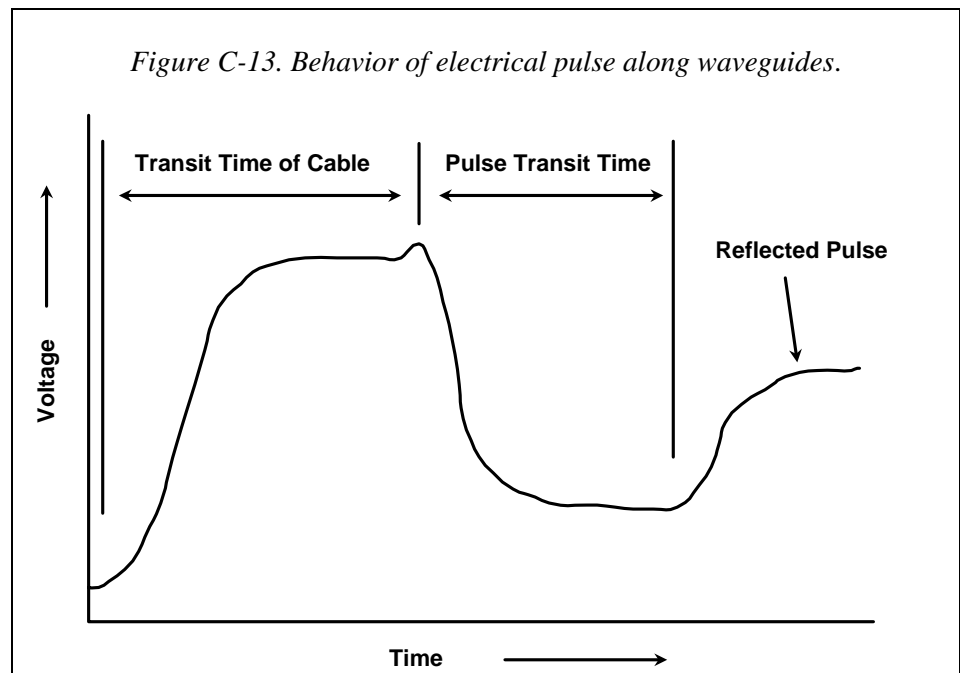

Most TDR sensors contain two to four waveguides. Lengths can range between a few inches to several feet. Keeping the probes parallel during installation may be difficult for lengths longer than two or three feet. The dielectric constant and thus the soil moisture is averaged along the waveguide's length. Measurements at specific depths can only be made by using very short waveguides, which may affect the accuracy of the measurement, or by installing longer waveguides horizontally into the soil, not practical for irrigation scheduling purposes.

A calibration equation has been developed for TDR systems that relate the dielectric constant and the soil moisture content. This equation has been found to be valid for a wide range of soil textures. Some discrepancies may exist between the calculated soil moisture content and the actual moisture content for values less than about 5 percent, generally too dry to be of little interest for irrigation scheduling purposes. Site-specific calibration may be required for soils with high iron contents or high organic matter content such as peat soils.

The zone of influence appears to be very small for a TDR sensor. Most of the response reflects the soil moisture within about one inch from the waveguide. Thus, the zone of influence of a one-foot long probe is a strip one-foot long extending about one inch beyond the waveguides. The width of the strip depends on the distance between the waveguides. Because of this small zone, an air gap between the waveguide and the soil can adversely affect its measurements.

The electrical conductance of a soil can affect the performance of a TDR system by attenuating the amplitude of the reflected TDR signal. Some studies have investigated using this behavior to measure soil salinity. However, relatively high levels of soil salinity may severely attenuate the reflected TDR signal such that the travel time cannot be measured. Under these conditions, TDR sensors cannot be used to measure soil moisture content.

Advantages of the TDR sensor are its ability to be left in place to continuously measure soil moisture content; its ability to make easy and rapid measurements; the use of a “universal” calibration equation; and its depth-averaged soil moisture content. Disadvantages include the relatively small zone of influence; its sensitivity to air gaps between the waveguide and soil; and signal attenuation caused by soil salinity.

Waveguides can be installed successfully from the surface to 18-24 inches. Deeper depths require digging a pit after which the waveguide pair or all-in-one sensor is inserted into the undisturbed pit wall or bottom. This necessary soil disruption can change both water movement and extraction patterns resulting in erroneous water use/recharge readings.

### Some Types of Instruments

Costs of TDR systems may range from \$500 to \$600 to thousands of dollars depending on the system.

*GroPoint* (Environmental Sensors, Canada). This time domain sensor consists of a U-shaped electrode with a rod located within the U (see *Figure C-14*). A hole is augured to the desired depth of installation, the sensor inserted into the hole, and the hole is backfilled. The soil must be carefully packed around the electrodes to prevent any air gaps. This instrument can be used with a hand-held meter or with a low-cost data logger. The data logger can be downloaded into a shuttle, which then can be downloaded into a computer at some other time. Costs of the sensor are from \$200 to \$300, the data logger from \$300 to \$400, and the hand-held meter is \$261. Advantages of this sensor are its relatively low cost and accuracy. Disadvantages are the need to disrupt the soil and roots to install the sensor.

*Figure C-14. GroPoint dielectric soil moisture sensor.*

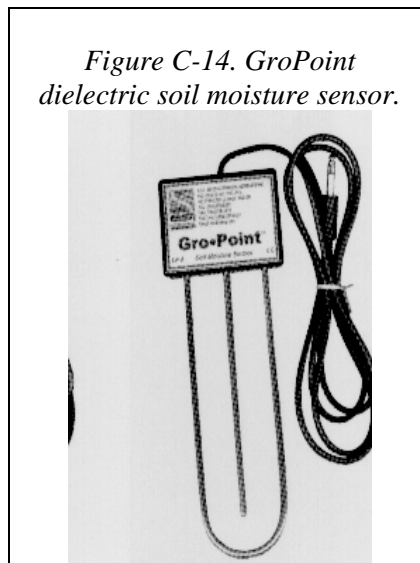

*Aquaterr Moisture Meter* (Aquaterr Instruments, Fremont, CA). This capacitance meter consists of a steel rod containing two electrodes at its tip. The rod is pushed into the soil to the desired depth of measurement. A pilot hole may be needed if the soil surface is too dry. This device provides a qualitative reading of soil moisture between 0 (dry soil) and 100 (water). A color-coded chart relates meter reading to degree of wetness for different soil types. Advantages of this soil moisture sensor are its low cost compared to other

dielectric instruments -- about \$500 -- and its portability, thus allowing measurements to be rapidly made at many locations in a field. Its portability, however, can be a disadvantage for making measurements over time because of soil variability. In dry soils insertion to any meaningful depth is difficult.

*Enviroscan* (Sentek Pty Ltd) and *C-Probe* (Adcon Telemetry, Boca Raton, FL). These capacitance sensors consist of a series of cylindrical electrodes installed in a PVC access tube. The sensors are located at the desired depths of measurement, and are left in place for the irrigation season. A cable connects the sensors to a data logger powered by a solar panel and battery. The data can be downloaded to a computer via a data pod or through telemetry to obtain the measurements of soil moisture content. An advantage of this device is its ability to make continuous measurements at small time intervals. Disadvantages include its cost (about \$1600 for the basic single station unit and up to 4000 for a full weather station including the soil monitoring probe) and the difficulty in installing the access tube without any air gaps.

*Diviner 2000* (Sentek Pty Ltd). This capacitance sensor uses the same technology, as does the *Enviroscan*. However, this sensor is portable and uses one set of electrodes. Measurements are made by lowering the sensor down a PVC access tube. As the sensor is lowered, measurements of depth below the ground surface and soil moisture content are made and recorded in a small computer. After the measurements are made, the sensor is removed from the access tube, and measurements then can be made at another location. One sensor can be used at many different locations

*Sentry* (Troxler Electronic Laboratory, North Carolina). This capacitance meter consists of a probe containing two cylindrical electrodes. The probe is lowered into a PVC access tube (2-inch Schedule 40) to the desired depth of measurement. One instrument can be used for many different access tubes, similar to using the neutron moisture meter. Calibration is provided for sandy soils but an adjustment may be needed for finer-textured soils. Advantages of this instrument are its relatively low cost (about \$3,000 to \$4,000); its portability; and its flexibility in making measurements at different depths. Disadvantages included the difficulty in installing the access tube such that no soil compaction or air gaps exist, and its limited calibration.

*TRASE System* (Soilmoisture Equipment Corp., Santa Barbara, CA). This TDR instrument requires driving two steel rods parallel to each other into the ground. The soil moisture content is averaged over the length of the rods. Maximum recommended depth of installation is about three feet because of the difficulty of keeping the rods parallel for deeper installations. The waveguides can remain in place during the duration of the irrigation season. The advantages of this instrument are its relative ease of installation compared with other dielectric instruments; and its averaging over the probe length which is desired for irrigation scheduling purposes. Disadvantages include the difficulty in removing rods and its cost.

*ThetaProbe* (Delta-T Devices Ltd, Cambridge, England; marketed by DYNAMAX, Houston, TX). This sensor contains four small steel rods installed at the end of a short section of PVC pipe. A cable connects the sensor to a hand-held readout instrument. A hole is augured down to the desired depth, and the instrument is pushed into the soil at the bottom of the hole. The probe can be left in place for the irrigation season or used to periodically sample at various locations or various times. The sensor can be connected to a data logger or read with a hand-held meter.

*ECH<sub>2</sub>O Aquameter (Decagon) Pullman, Washington;* The *ECH<sub>2</sub>O* sensor measures the dielectric constant of a medium by finding the rate of change of voltage on a sensor that is embedded in the soil at a specific depth. The sensors measure the area of the device, which is available in 10 and 20 cm lengths. For shallow installations they can be inserted directly into undisturbed soil. For deeper installations they are inserted permanently into the bottom of an auger hole. An installation kit provides the necessary tool to provide good soil contact. Auger hole should be carefully backfilled to minimize water movement from the surface. Handheld meters, data storage modules and telemetry are available. Prices are about \$100 per sensor and \$375 for a handheld sensor and \$425 for a data logger.

### ***Field Evaluations***

Field evaluations of some of these dielectric sensors were conducted at six sites in the San Joaquin Valley. Three sites, located on the eastside of the valley, were loamy sand or sandy loam, while the other sites were silt loam and silty clay, located on the westside of the valley. The instruments' readings were compared with the soil moisture content measured with a neutron moisture meter calibrated for each site.

Results showed that the dielectric instruments were reasonably accurate in coarser-textured soil. However, in fine-textured soil, capacitance sensors can be very inaccurate. In some cases, they may not work at all.

The bottom line is, before investing money in dielectric sensors to monitor soil moisture content of fine-textured soils, be sure that the instrument will work under the particular conditions. Some calibration may be necessary for accurate measurements.

## ***Sensor Placement and When to Measure***

### ***Sensor Placement***

Moisture sensors vary in the volume of soil from which the measurement is made. The smallest include the resistance block and tensiometer. The soil contact with the sensor determines the volume of soil used for the determination, in this case, only a few cubic inches. Other devices such as the Neutron moisture meter and dielectric constant moisture meters average a larger area. A neutron probe, depending on soil moisture content, measures about a ten-inch diameter area at a single measurement location. The zone of influence of Dielectric sensors is restricted to a narrow disk-shaped region surrounding the sensor and centered on the gap between the electrodes. Some uncertainty exists on the distance from the sensor over which the soil moisture content affects the sensor's reading. However, the sensor is most sensitive to the soil moisture content of the soil immediately adjacent to it. This sensitivity means that any air gap between the sensor and the soil will greatly affect the instrument's performance. TDR methods measure between the waveguides to the depth installed as deep as 18 to 24 inches.

Single point devices require multiple instruments be installed at a number of placements in the root zone to adequately characterize the soil moisture. Typically, single point instruments are installed in the top third, middle third, and lower one third of the root zone. Devices that use an access well inserted to the bottom of the root zone or deeper can be set to measure at any soil depth.

**When and  
How Often to  
Take a  
Reading**

Measurements can be made with all instruments at any time; however, the reading times should coincide with specific times of the year or irrigation events to be most useful. These times might be by date before irrigation begins to measure vine water extraction or by events such as bud break or harvest.

Measurements made at bud break are at a time when the soil moisture is evenly distributed horizontally in the root zone. Another way to visualize this is that a reading at a specific depth will be representative of the same depth over the entire area. A cover crop or resident vegetation can disrupt this even horizontal distribution leading to an overestimation of soil moisture if the measurement is measured in the clean berm area.

As the vine begins to use moisture, it first extracts from the shallow depths where the highest root densities exist. As the soil dries in these areas, extraction is switched to areas of lesser root density but higher water availability. This pattern continues without irrigation until the soil is quite dry with the remaining soil moisture at the deeper depths.

A measurement made when the soil is relatively dry prior to the first irrigation can be used to determine:

- 1) the volume of water used since bud break (bud break measurement – current measurement)
- 2) the amount remaining in the soil which can be removed by harvest (current measurement – harvest measurement).

Once irrigation begins by applying water to the soil from a non-full coverage irrigation system (drip/micro sprinklers) the soil is recharged non-uniformly. Measurements at this time are valuable to determine the depth of water penetration and size of wetted area if multiple wells are used. Readings to determine water use between two measurement times is not valid since the soil is not uniformly wetted (*Figure C-15*). In order to determine the soil water depletion under these conditions a number of measurements encompassing the entire root zone would be necessary to calculate the average root zone water content.

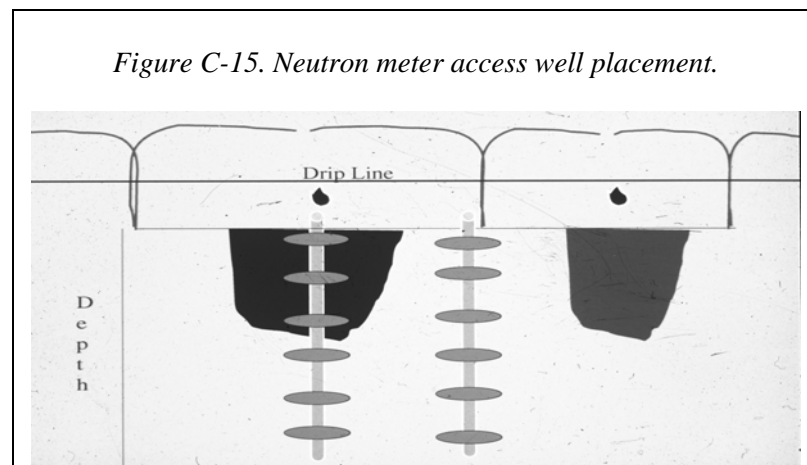

# Measuring In-Season Rainfall

## In-Season Effective Rainfall

In-season rainfall is that which occurs after bud break and before leaf fall. However, not all rainfall is stored in the root zone and is available for use by the vine. In irrigation scheduling, the term "*effective rainfall*" refers to that portion of rainfall, which infiltrates and is stored in the root zone. Effective in-season rainfall reduces the irrigation requirement. Since rainfall is spatially quite variable in during the growing season effective rainfall must be estimated for each field and rainfall event. This task however, is difficult since the climatic conditions during and after the event determine the volume of water, which will be stored in the root zone for vine use. Factors like the soil type the amount of surface mulch and cover crop, rainfall duration and intensity as well as evaporation conditions immediately after the event each influence the volume of effective rainfall. Effective rainfall occurring when the soil reservoir is full is lost to drainage or runoff.

Measuring effective rainfall using soil moisture devices is imprecise since the amount is usually small and is stored near the soil surface where devices such as neutron probe meters are ineffective. Using a deficit-threshold plus RDI irrigation method requires the estimation of effective rainfall from the irrigation threshold through harvest. This is a time with limited significant rainfall events. Soil sampling methods are best used after the surface has dried a few days; however, the vine can be using the moisture during this period leading to errors. Many complex methods exist for calculating effective rainfall, which requires many climate and soil variables. Most were developed for midwestern dryland agriculture.

The most practical method to estimate effective in-season rainfall for vineyards is using the formula:

$$\text{Effective Rainfall} = [\text{rainfall (in)} - 0.25 \text{ in}] \times 0.8$$

This method discounts the first 0.25-inch as lost to evaporation after the event and estimates 80% of the remainder is stored in the soil. Most scheduling programs only begin to account for effective in-season rainfall after irrigation begins the chance of significant rainfall during this period is low in most areas of California. *Table C-3* shows the calculation of effective rainfall for a one-week period of time.

Day	Rainfall (inches)	Effective Rainfall (inches)
1	0.39	0.11
2	0.62	0.30
3	0	0
4	0	0
5	0	0
6	0	0
7	0.25	0
Weekly Total	1.26	0.41

## Measuring Irrigation Water

Measuring the water delivered to an area of land can be done using water flowmeters, measuring individual emitter discharge and using estimates based on measured pump performance and power records.

### Flowmeters

Flowmeters measure the volume of water moving through a full-flowing closed pipe and as such are one of the key components of a drip irrigation system. They are essential for managing irrigation efficiently and for monitoring the performance of the irrigation system. Managing irrigation efficiently requires: (1) knowing how much water the crop has used since the last irrigation (irrigation scheduling); and (2) operating the irrigation system to apply only the amount of water desired. A flowmeter gives the manager the information needed to apply only the amount of water required.

Monitoring the performance of a micro-irrigation system makes it possible to identify changes in flowrate during the season (measured at the same pressure), which may indicate problems such as clogging of emitters or filters, leaks in the system, or problems with the pump or well.

#### Propeller Flowmeters

Propeller flowmeters, consisting of a propeller linked by a cable or shafts and gears to a flow indicator and inserted into a pipeline, are frequently used to measure flowrates in pipelines. The indicators can report either the flowrate or the total flow volume, or both.

Propeller flowmeters can be installed in several different ways: by being inserted into a short section of pipe, which is then either coupled (*Figure C-16*); bolted (*Figure C-17*) into the pipeline; clamped, strapped, or welded onto the pipeline as a saddle-type meter (*Figure C-18*); or inserted into the pipe discharge (*Figure C-19*) to measure flow from gates installed in canals and ditches.

*Figure C-16. Welded propeller flowmeter.*

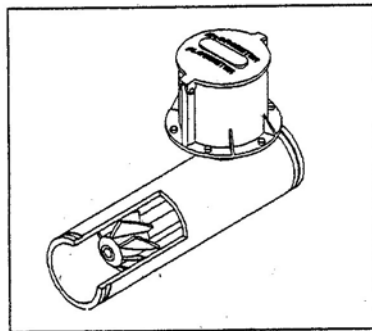

*Figure C-17. Bolted propeller flowmeter.*

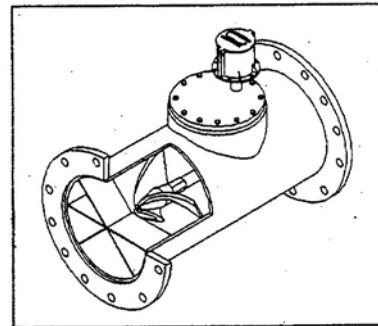

*Figure C-18. Saddle-type propeller flowmeter.*

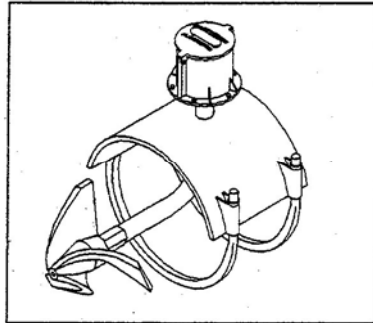

*Figure C-19. Insertion-type propeller flowmeter.*

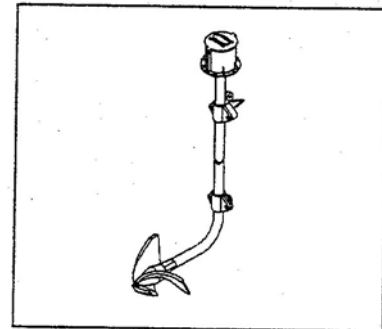

*Illustrations courtesy of Ketema/McCrometer Division, Hemet, CA 92545*

Propeller meters can also be installed as in-line meters in a short section of portable pipe (*Figure C-16*). Couplings are welded onto each end of the flowmeter pipe section to connect sections of the portable pipe. One flowmeter of a given size can be used for several sizes of portable pipe if a sufficiently long straight section of pipe of the same diameter as the flowmeter section is installed immediately upstream from the flowmeter.

Since clamp-on and strap-on saddle meters can be moved from location to location, one flowmeter can be used to measure flowrates for several pumping plants. The same pipe diameter must be used at each site, however. Dummy saddles can be installed at locations other than the one at which the meter is installed.

### **Selecting Propeller Flowmeters**

Propeller meters must be matched to the correct pipe size — since the gear mechanism connecting the propeller to the indicator is based on the pipe inside diameter — and to the desired flowrate. *Table C-4* gives maximum and minimum flowrates for various pipe diameters.

Most flowrate indicators report in gallons per minute or in cubic feet per second, while total flow indicators (“totalizers”) report in gallons, acre-feet, or cubic feet. Some indicators report in metric units.

### **Installation and Operation**

The flowmeter should be installed at a location of minimal water turbulence, since too much turbulence will cause the flowrate indicator to oscillate wildly, preventing reliable measurement.

Manufacturers often recommend that a section of straight pipe, eight to ten pipe diameters long, be placed immediately upstream from the flowmeter, but field experience has shown that a longer pipe length may be required in locations where jetting may occur because of a partially closed valve. One manufacturer maintains, however, that reliable measurements can be made with even relatively short sections of pipe if straightening vanes are used.

*Table C-4. Flowmeter maximum and minimum flowrates for various pipe diameters.  
(Courtesy of McCrometer Flowmeters)*

Meter and nominal pipe size	4	6	8	10	12	14
Maximum flow rate	600	1200	1500	1800	2500	3000
Minimum flow rate	50	90	108	125	150	250

**Swirling**

A centrifugal sand separator or a series of elbows in the pipeline may cause a swirl or rotation to develop in the flowing water. The swirls may still be present even one hundred pipe diameters downstream. The remedy is to place straightening vanes in the pipeline just in front of the flowmeter. One manufacturer recommends that a six-vane straightener be used.

A relatively stable propeller meter rate indicator means that turbulence is minimal, but wide variation in indicator readings signals turbulence in the pipeline. If the rate indicator shows erratic, violent behavior, air or gas may be present in the water.

**Attaining Full Flow**

Propeller flowmeters will operate properly only if the pipe is flowing full. If the pipeline is only partially full, the flowrate measurement will not be accurate. In pressurized irrigation systems, flow will usually be full at the pump discharge, but in pumps with an open discharge, as into an irrigation ditch, pipe flow may not be full. The problem can be remedied by creating a slight rise in the discharge pipe; by installing a gooseneck at the pipe discharge; by installing an elbow (discharge end pointing upward at the pipe discharge); or by installing a valve downstream from the meter.

**Accuracy**

Under ideal conditions, a propeller flowmeter operated within its recommended range can be accurate to within  $\pm 2$  percent, but if the flowrate is too slow, accuracy will be less.

**Pressure/Head Loss**

Inserting a propeller into the water flow can cause friction, resulting in pressure or head losses in the pipeline. The amount of pressure lost depends on the velocity or flowrate and on the pipe diameter. The higher the flowrate, the more pressure lost because of the flowmeter, but the larger the pipe diameter, the less pressure lost.

As *Figure C-20* illustrates, these pressure losses are generally small. With a ten-inch flowmeter, the pressure loss is less than 0.1 psi for flowrates less than 2000 gpm.

Figure C-20. Pressure loss caused by propeller flowmeters.

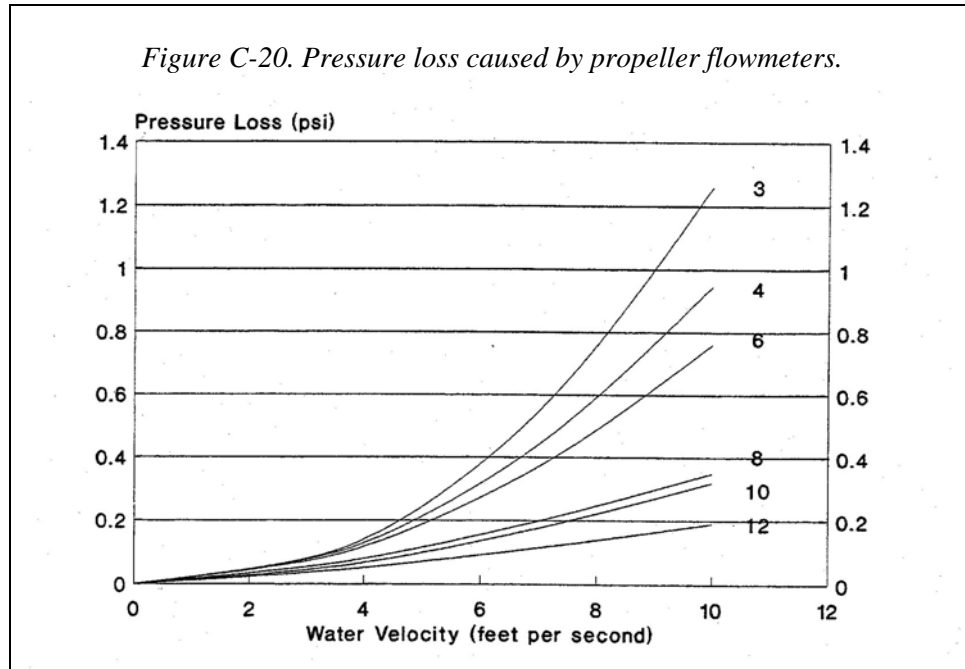

(Figure developed from data supplied by Water Specialties Corporation, Porterville, CA 93257.)

**Magnetic Flowmeters**

The recently introduced magnetic flowmeter has the advantage of not causing an obstruction in the pipe. This feature eliminates the problem of possible entanglement from debris in the water as well as any pressure loss across the device. Magnetic flowmeters also require less maintenance than propeller meters, have long-term accuracy, and can be installed only five pipe diameters of straight pipe upstream from the meter, but have the disadvantages of a higher initial cost and the need for an external power supply.

**Ultrasonic Flowmeters**

Ultrasonic flowmeters measure flow velocity (and thus flowrate) by directing ultrasonic pulses diagonally across the pipe both upstream and downstream. The difference in time required for the signal to travel through the moving water is measured and converted to flow velocity. Ultrasonic flowmeters have accuracy comparable to that of propeller meters and, since they have no moving parts, require little maintenance. Because all attachments are external, these meters can be moved easily to different locations. Since the ultrasonic meters work by bouncing the ultrasonic pulses off particles in the water, irrigation waters, which don't have enough suspended particles in it, may not be appropriate for ultrasonic meter use. It has been found that high quality well waters may fall into this category. Ultrasonic flowmeters generally cost more than other types of meters.

**Turbine Flowmeters**

Turbine flowmeters operate on the principle of a rotor assembly, turning at a rate proportional to the flowrate in the pipelines. The rotor is suspended near a magnetic pickup, which records a pulse on its readout unit as each rotor blade passes. Turbine flowmeters have an accuracy comparable to that of propeller flowmeters (within a few percent) under the correct flow conditions and require a ten-pipe diameter length of straight pipe upstream and a six-pipe diameter length downstream. The turbine flowmeter is more sensitive to non-uniform flow conditions, such as exist downstream of an elbow or constriction, than is a propeller flow meter. Some turbine flowmeters can be

installed in a range of pipe diameters, which provides flexibility in their use. The applicability and cost are comparable to that of a propeller meter.

**Venturi  
Flowmeters**

Venturi flowmeters consist of a section of pipe with a restriction in a specific shape, across which pressure change is measured. The magnitude of this pressure change depends on the flowrate through the device. Venturi flowmeters offer the advantages of unobstructed water flow, no moving parts (meaning low maintenance requirements), little pressure loss across the device, and good accuracy. Venturi flowmeters cost slightly more than propeller meters and the meter readout is less convenient than that of some other flowmeters.

**Converting  
Flowmeter  
Readings**

The readout from flowmeters can be in instantaneous flowrate in gallons per minute (gpm) or cubic feet per second (cfs), or in total flow in gallons, cubic feet, or acre-feet. For irrigation scheduling purposes, however, crop water use is given in inches or in inches per day. The following formulas can be used to convert flowmeter readout to inches per hour.

$$\text{___ gpm} \div \text{area irrigated (acres)} \times 0.0022 = \text{___ in/hr (see also Table C-5).}$$

$$\text{___ cfs} \div \text{area irrigated (acres)} \times 0.992 = \text{___ in/hr (see also Table C-6)}$$

$$\text{___ gallons} \div \text{time period over which measured (min)} \div \text{area irrigated (acres)} \times 0.0022 = \text{___ in/hr}$$

$$\text{___ cubic feet} \div \text{time period over which measured (minutes)} \div \text{area irrigated (acres)} \times 0.0165 = \text{___ in/hr}$$

$$\text{___ acre-feet} \div \text{time period (minutes)} \div \text{area irrigated (acres)} \times 720 = \text{___ in/hr}$$

**Using the  
Flowrate to Find  
Out How Much  
Water is Being  
Applied During  
an Irrigation Set**

From the flowrate measurement, the amount of water applied during an irrigation set can be calculated in inches using the following equation:

$$D = (Q \times T) \div (449 \times A)$$

- where: D = inches of applied water  
 T = actual hours required to irrigate the field  
 A = acres irrigated  
 Q = flowrate in gallons per minute

**Example**

Calculate the inches of water applied if a flowrate of 300 gallons per minute is used to irrigate 40 acres in 16 hours.

$$D = (300\text{gpm} \times 16\text{hours}) \div (449 \times 40\text{acres}) = 0.27\text{inches}$$

## References

Ketema/McCrometer Division. *McCrometer propeller flowmeters: manual for installation, operation, and maintenance.*

Ketema/McCrometer Division. *Bulletin G1200. Basic specifications for McCrometer propeller flowmeters.*

Ketema/McCrometer Division. *Bulletin MR-300. McCrometer flowmeters.*

Noffke, Milvern H. 1991. "Achieving accurate irrigation water measurements with propeller meters." ASCE Specialty Conference, *Planning Now for Irrigation and Damage in the 21st Century*, July 18-21, 1988, Lincoln, Nebraska.

## ***Measuring Emitter Discharge***

Measuring individual emitter discharge can be easily done with a graduated container and a watch that displays seconds. The container can be a graduated cylinder (100 ml works best), a graduated measuring container (often used for spraying) or a 35 mm film canister. A number of emitters should be measured throughout the block to establish an average discharge rate. Flow rate varies with changes in pressure due to elevation changes, and friction loss in the system. Emitter clogging as well as manufacturing variation also will influence flow rate.

- Collect water for 30 seconds in a 100 ml graduated cylinder (see *Table C-5*) or time how long it takes to fill a 35 mm film canister (see *Table C-6*). Use either table to convert the amount of water collected from each sampled emitter to the discharge rate for that emitter
- For each irrigation block, average all your discharge rate measurements. This is the average emitter discharge rate (gph) of your emitters.

*Table C-5. Drip emitter discharge rate (gallons per hour – gph) using a graduated cylinder)\**

ml of water collected in 30 seconds	Drip emitter discharge rate (gph)	ml of water collected in 30 seconds	Drip emitter discharge rate (gph)
10	0.32	26	0.82
12	0.38	28	0.89
14	0.44	30	0.95
16	0.51	32	1.01
18	0.57	34	1.08
20	0.63	36	1.14
22	0.70	38	1.20
24	0.76	40	1.27

$$\text{Drip emitter discharge rate (gal/hr)} = \frac{\text{Water (ml) collected in 30 seconds}}{30} \times 0.0317$$

\* A 100 ml graduated cylinder works well

*Table C-6. Drip emitter discharge rate (gallons per hour - gph) using a 35 mm film canister*

Seconds to fill 35 mm film canister	Drip emitter discharge rate (gal/hr)	Seconds to fill 35 mm film canister	Drip emitter discharge rate (gal/hr)
26	1.28	48	0.69
28	1.19	50	0.67
30	1.11	52	0.64
32	1.04	54	0.62
34	0.98	56	0.59
36	0.92	58	0.57
38	0.88	60	0.55
40	0.83	62	0.54
42	0.79	64	0.52
44	0.76	66	0.50
46	0.72	68	0.49

$$\text{Drip emitter discharge rate (gal/hr)} = \frac{33.29}{\text{Time to fill 35 mm film canister (seconds)}}$$

## D. Vine Water Deficits Caused by Reduced Soil Water Availability

### *Winegrape Water Use*

Winegrape water use is driven by a vine's canopy exposure to the energy of the sun. The vine encounters this energy as direct radiation from the sun and indirect radiation sources such as heated low humidity air, and wind. The combined effect of these energy sources on the vine canopy determines vine water use when soil moisture is not limited.

The intensity of these atmospheric factors varies over the day as well as over the season and can be measured and used as input to an empirical model to calculate relative water demand. The result, termed the reference evapotranspiration (ET<sub>o</sub>), most closely approximates a full coverage grass crop and will vary over the season. Normal or average years ET<sub>o</sub> data is shown for Lodi California in *Figure D-1*. Water use is also influenced by vine canopy growth from bud break to full canopy expansion. Together these factors contribute to a water use pattern that begins at a low rate in spring, peaks in mid-summer and then declines as leaf drop approaches (*Figure D-2*). For this discussion, we will assume the canopy is at a full practical midday land surface shading of 50 percent at maximum canopy expansion. This level of land surface coverage is a large wine grape canopy but still allows for standard vineyard cultural operations. Land surface shading can be measured mid-day as the percent of shade on the vineyard floor. Shading is predominately influenced by row spacing and vine vigor; however, canopy management practices (such as hedging or canopy disruption by machine harvesting) can further modify this pattern by reducing the energy intercepted by the vine.

Vine water use is reduced below full potential when soil moisture is limited and irrigation is not supplied. *Figure D-3* illustrates both the full potential water use and the water use of a deficit irrigation regime on a weekly basis. Early season water use is similar between the two regimes since adequate moisture is available in the soil. When soil moisture becomes limited in mid-season, differences in water use can be seen. Irrigation can be applied to significantly influence the differences shown in water use. *Figure D-4* illustrates seasonal cumulative water use of the same vineyard in the Lodi area with adequate soil moisture for the entire season and one of a deficit irrigation regime. Notice the near 30 percent seasonal difference in water use between full potential water use and a deficit irrigation regime over the season.

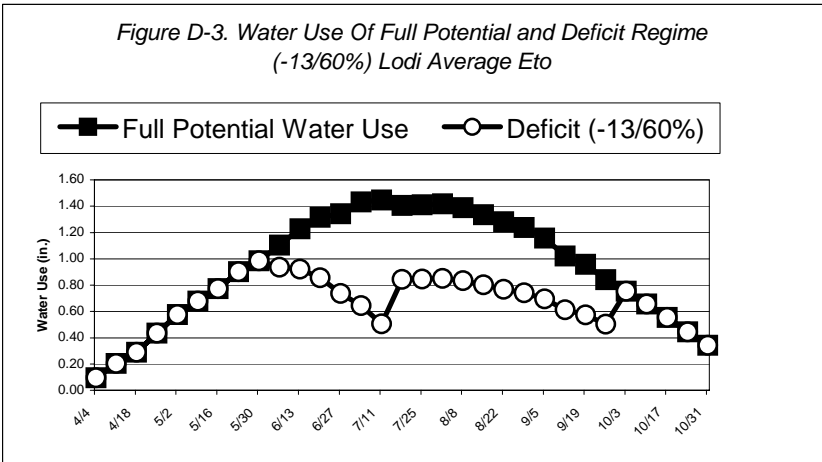
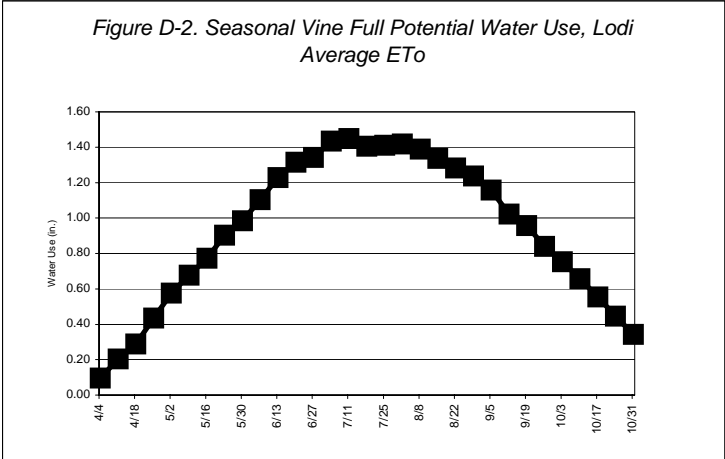
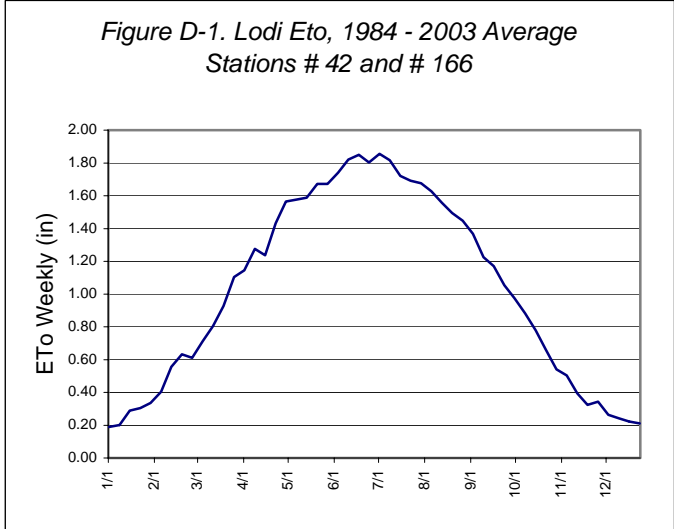

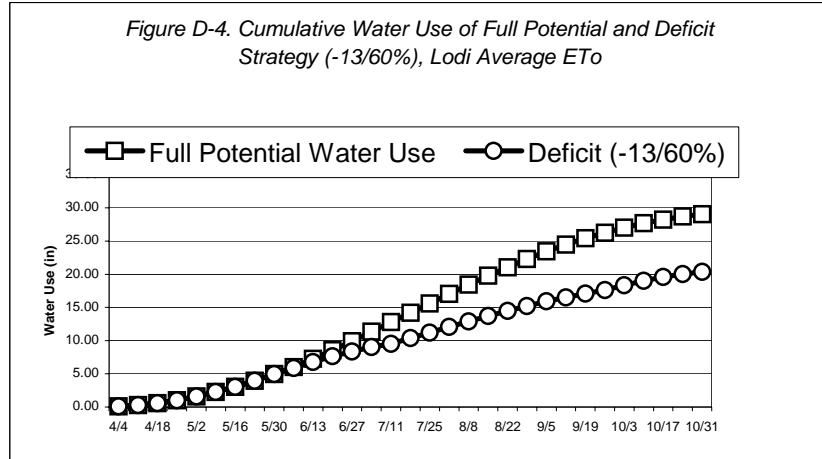

## Vine/Fruit Growth and Development

The growth of shoots and leaves begins shortly after bud break. Growth proceeds at a high rate then declines to near zero as veraison is approached (*Figure D-5*). Nearly one-half the shoot length is attained by flowering. Berry growth rate increases after flowering in an initial rapid period of growth (Stage I). In the next stage (II), growth rate is much slower followed by another rapid growth period (Stage III) near veraison. Vegetative growth rate of the shoot continues to decline in berry Stage I and is virtually none existent during Stage III. Root growth, measured as the number of actively growing root tips per square meter of soil, has two distinct high growth rate periods—one at flowering and another near and post harvest. Recent research has shown a continual turnover in root numbers for the entire season.

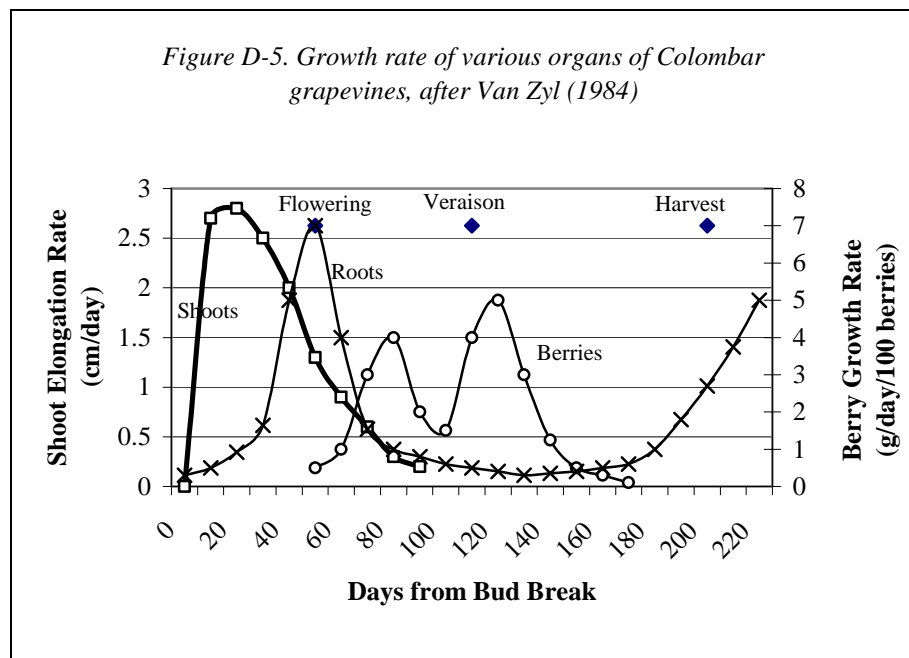

Berry ripening begins at veraison. The berries begin to soften, change color and begin to accelerate in growth during this third and last stage of growth (Stage III, *Figure D-6*). Berries decrease in titratable acidity (TA) and increase in pH and soluble solids (brix) as harvest is approached. If water is abundant, lateral shoot growth can continue during this period.

Most soils can provide adequate water for basic shoot growth, root growth, and berry cell division up to a month before veraison (Stage I). During berry development (Stage II), for a 3-week period leading up to veraison, water deficits can reduce main and lateral shoot growth. Limiting main shoot growth to near one meter in length provides adequate leaf area to mature the crop. Limiting growth of the main shoot and laterals provides more light to the fruit, increasing anthocyanins and phenolics for increased wine color and character. Another way to access adequate shoot growth is to determine the leaf area per weight of fruit. Between 0.8 – 1.2 m<sup>2</sup>/kg fruit for a single canopy and 0.5 -0.8 m<sup>2</sup>/kg for divided is considered optimal (Dokoozlian 1996).

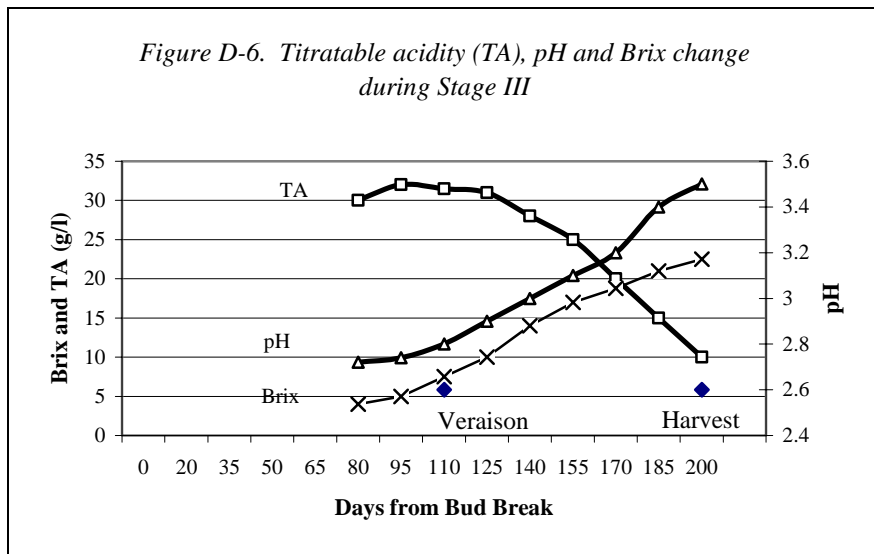

## *Effects of Vine Water Supply on Vine and Fruit*

***Vine  
Response to  
Water Deficits***

The effects of vine water deficits can be both beneficial and harmful to the crop, depending on their timing and severity. When water deficits occur, the vine responds by closing pores in the leaf, called stomata to limit water loss. This closing of stomata reduces water loss, creating a better balance between water demand and moisture extracted by the roots. This strategy of moderating the severity of water deficits works well initially, generally limiting the effects of water deficits to a reduction in vegetative growth. As water deficits increase in severity and duration, the stomata are closed for longer periods of time. Since the stomata are the entry points for carbon used in photosynthesis, severe water deficits limit the time the stomata are open which limits photosynthesis and the production of sugar.

## *Vegetative Growth*

### **Water Deficit Severity**

In areas of moderate climatic water demand or adequate soil water increases, deficits can be mild and expressed by a reduction of vegetative growth.

In areas of higher climatic water demand or in soils of limited water storage, deficits can occur sooner and be severe enough to cause reduced photosynthesis and partial or complete defoliation.

Water deficits can be moderated by irrigation.

Water deficits occurring early season (bud break to fruit set) are not usually possible in most viticultural regions as previously discussed. Midseason (fruit set to veraison) water deficits are possible in soils that are shallow or coarse textured with limited (soil) water holding capacity. In low rainfall areas and during drought years, midseason deficits are possible even in deep soils. During this period, shoot development (both main shoot length and the number and length of lateral shoots) can be restricted by water deficits. Reduced canopy development can result in reduced leaf area, which may be insufficient to develop and mature fruit in low vigor situations. In years with low amounts of stored water at bud break irrigation may be needed to attain adequate shoot growth. However, when vine vigor provides adequate to more than adequate canopy to support the crop load, restricting or controlling additional canopy (leaf area) may be desirable.

More severe water deficits, occurring in the period between veraison and harvest, can result in senescence of lower and interior canopy leaves providing more light to the fruit. Some loss of leaves in the fruit zone may occur without significantly reducing sugar accumulation. Moderate amounts of irrigation water during this period can successfully moderate water deficits, causing the desired effect of inhibiting further shoot growth without reducing photosynthesis or causing defoliation. Excessive water deficits can cause defoliation, which can lead to sunburn, “raisining” or increased berry temperature, all causing reduced fruit quality.

Irrigation volumes should be adjusted to moderate, not eliminate, the deficit. Excessive irrigation during this period may cause lateral shoot growth to resume, creating a competitive sink for photosynthate, which can increase shading, cause bunch rot in susceptible varieties, delay fruit maturation and harvest. Effects on the wine are poor color/character and veggie flavors.

### **Timing of Water Deficits**

Midseason, moderate water deficits can cause reduced vegetative canopy growth, allowing increased fruit exposure to light without limiting photosynthesis. Later season water deficits can reduce leaf cover in the fruiting zone.

### **Severity of Water Deficits**

It is apparent that moderate, midseason vine water deficits can have a beneficial effect by reducing vegetative growth and limiting lateral growth. If too severe, deficits in mid to late season can restrict sugar accumulation or cause excessive fruit exposure.

A continued or increasing water deficit following harvest provides little or no benefit to vine and next year's crop. Root growth, which increases after harvest, can be restricted and can result in early season nutrient deficiencies the following spring. In colder areas, low temperature injury of permanent wood fruiting structures can also result if too little or excessive water is applied post harvest.

### **Berry Growth**

Berry growth begins after flowering and pollination. Growth progresses at a rapid rate for 40-60 days. In this period, called Stage I, a berry diameter may double in size. Stage II follows for approximately 14-40 days where the growth rate slows or stops, often call the "lag" phase. The onset of Stage III is marked by veraison lasting until harvest (typically a 35-55 day period) in which berry growth resumes. Berry growth is less sensitive to water deficits than vegetative growth. However, depending on the timing and severity of water deficits, berry size can be reduced.

Water deficits during Stage I of fruit growth are thought to reduce potential berry size by reducing the number of cells per berry. The reduction in cell number causes smaller berries and almost always causes a reduced yield. However as previously mentioned, water deficits at this time are unusual in most winegrape regions of California. In years with low amounts of stored water at bud break irrigation may needed to prevent significant berry size and therefore yield reduction. Water deficits occurring during Stage II (lag phase) or III (cell enlargement) can only affect cell size. The common effect of moderate water deficits during these later periods is to slightly reduce berry (cell) size. Severe water deficits can cause reduced berry size at harvest by dehydration.

### **Yield**

Reports on the effect of water deficits on yield are varied. Results from both California and Australia indicate white varieties (Chenin blanc, Thompson Seedless and Chardonnay) maximize yield at near 60-70 percent of full potential seasonal vine water use. With the remainder of the consumed water supporting increased vegetative growth. In red varieties, water deficits at the same level have been shown to slightly decrease yield (3 to 19%) from that of full potential water use. It is important to note the 4 year average yield reduction of 19% was from a 10 to an 8 ton per acre Cabernet Sauvignon yield. The quality of the 10-ton crop was very poor. Additionally, t yield reductions generally require moderate deficits to be repeated for one to two years before the yield reduction occur. Berry size is the most common cause of yield reductions in yield however fruit load, reported as the berries per vine, can also be responsible. Severe water deficits can reduce yield in the subsequent season as a result of reduced fruit load measured as cluster number and berries per cluster (and therefore, berry numbers). Yield reductions in red varieties have been associated with increased fruit quality while full potential water use results in reduced fruit quality expressed as reduced wine color and character.

#### **Symptoms of Water Deficits**

- Decrease in the angle formed by the axis of the leaf petiole and the plane of the lamina (blade)
- Internode growth is inhibited
- Reduced tendril growth in relation to the shoot tip
- Reduced number and length of lateral shoots
- Abscission of oldest leaves

**Fruit  
Composition**

Potential wine quality is largely determined by the composition of the fruit. The solute composition of fruit at harvest is sensitive to vine water status throughout its development. Moderate water deficits can increase the rate of sugar accumulation resulting in an earlier harvest. If deficits are severe and/or the vine is carrying a large crop, sugar accumulation is generally slowed resulting in delayed harvest since the final increases in sugar are mostly driven by berry dehydration rather than sugar production. The result is a fruit with poor balance of solutes and reduced wine quality potential.

Water deficits result in only moderate decreases in total acidity; however, malic acid is apt to decrease sooner with early season water deficits. Deficit irrigation causing moderate water deficits typically reduces malic acid concentrations in half (Figure D-7) More water stress at the threshold and lower RDI 35% further reduce malic acid content. With malic acid declining, the greatest effect of water deficits on the fruit is an increase in the tartaric to malic acid ratio. Juice acidity measured by pH, can also be reduced by water deficits.

Treatment (Threshold/RDI%)	Must Malic Acid Concentration(g/L)
Full potential	3.83
-13/60%	1.92
-13/35%	1.45
-15/60%	1.27
-15/35%	1.14

From Terry Prichard 2000

**Wine  
Color**

Water deficits can directly increase wine color by enhancing the production of pigments found in the skin of red wine varieties. Reductions in vine canopy using water deficits also allow diffuse light into the fruit zone, which increases skin pigment. Figure D-8 shows the increase in phenolics and anthocyanins in berries of cabernet franc grown in the north coast of California as a result of irrigation treatment. The early deficit treatment (pre-veraison) resulted in increased phenolics and anthocyanins over the control and the late deficit treatment. The continual deficit treatment further increased anthocyanins.

Treatment	Skin Phenolics mg/cm <sup>2</sup>	Skin Anthocyanins mg/cm <sup>2</sup>
Control(grower std)	0.46	0.51
Early Deficit (pre-veraison)	0.56	0.61
Late Deficit (post veraison)	0.52	0.59
Continual Deficit (pre and post veraison)	0.57	0.65

From Matthews and Anderson 1984

Table D-3 shows the result of a Cabernet Sauvignon trial conducted in Lodi where water stress was imposed and light at the fruit level and the wine hue and phenolics were measured as a consequence of treatment. The light measured at the fruit level was significantly reduced when compared to all of the deficit treatments. The increased light strongly correlates with improved hue and phenolics,

*Table D-3. Lodi Cabernet Sauvignon Light at fruiting level and wine analysis  
Treatments as a percentage of full potential water use with pre or post veraison deficits*

	Cumulative Light		Absorbance			Color Hue	Phenolics (Abs 280 nm)
			420 nm	520 nm			
T1 (100%)	1.32	d	0.162 d	0.169 f	0.962 a	29.9 c	
T2 (70%, post ver)	2.19	cd	0.227 bc	0.289 bc	0.789 bc	36.6 abc	
T3 (70%, Pre ver)	1.70	cd	0.226 bc	0.268 bcd	0.847 b	33.1 cde	
T4 (50%Post ver)	4.00	bc	0.295 a	0.373 a	0.790 bc	39.3 a	
T5 (50%Pre ver)	3.20	cd	0.250 ab	0.335 ab	0.745 c	38.2 ab	

Additionally, a decreased berry size may also indirectly contribute to improved wine color by a larger skin to volume ratio. In areas that experience severe climatic conditions for weeks at a time (Central Valley) excessive fruit exposure can raise the berry temperature, reversing the accumulation of pigments and causing poor berry color. Enhancement of color pigments (anthocyanins) and flavor compounds (phenolics) appears to be a consistent result of better light exposure.

## ***Vine Water Deficits Caused by Reduced Soil Water Availability***

As available water to the vine becomes limited through depletion of winter-stored soil water or irrigation water, a level of availability is approached where the vine cannot sustain the full potential water use. It is at this point that the vine begins to undergo a water deficit. Essentially, a deficit occurs when the evaporative demand is greater than the roots can absorb.

### **Water Deficits**

Water deficits occur when the energy expressed to the canopy creates a water demand that exceeds the vine's ability to extract moisture from the soil.

Under normal early-season conditions, (1) water is readily available in the root zone, (2) the vine is not at full canopy expansion, and (3) the atmospheric-driven demand is small. Therefore, under normal early season conditions, water deficits are uncommon in most if not all winegrowing regions of California. As the season progresses without irrigation, the canopy expands, climatic conditions intensify and the soil is further depleted of available water. It is at this time that the vine's water demand can exceed water uptake from the soil causing water deficits. Cooler growing regions and a greater volume of available water in the soil from winter storage or irrigation will cause water deficits to be postponed to later in the season. Generally, water deficits do not *begin* to occur until the vine has extracted about 50 percent of the available soil water contained in the root zone. Soil depth, texture and the total water stored in the root zone can influence this rule of thumb.

As water deficits begin, they occur only for a short period of time at the peak water demand period of the day. The vine recovers from water deficits initially by controlling the stomata in the leaves to limit leaf water loss. Additional recovery occurs when atmospheric conditions relax in the later part of the day and during darkness hours. This cycle continues each day, depending on the climate, available soil moisture and to some extent, root extensiveness. Without irrigation, the deficits become longer in duration and more severe as the season progresses. Water deficits are monitored using a pressure chamber to measure

midday leaf water potential. *Figure D-7* illustrates a typical mid season vine water status measured over a 24-hour period.

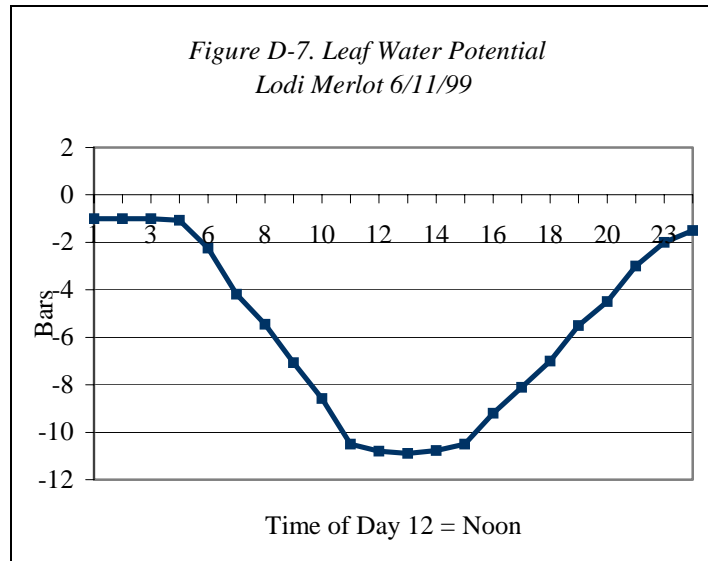

## ***Timing of Water Deficits***

A review of winegrape irrigation research yields two conclusions in comparing the timing of water deficits: 1) moderate pre-veraison to veraison water deficits usually produced higher quality fruit and therefore wines; and 2) were usually the “best option” treatment for maintaining yields. In all cases, severe late season water deficits were more risky in terms of fruit quality and yield.

### ***Early Season Deficits***

Under normal early-season conditions, (1) water is readily available in the root zone, (2) the vine is not at full canopy expansion, and (3) the atmospheric-driven demand is small. Therefore, under normal early season conditions, water deficits are uncommon in most if not all winegrowing regions of California.

### ***Pre-Veraison Deficits***

As the season progresses without irrigation, the canopy expands, climatic conditions intensify and the soil is further depleted of available water. It is at this time that the vine’s water demand can exceed water uptake from the soil causing water deficits. Cooler growing regions and a greater volume of available water in the soil from winter storage or irrigation will cause water deficits to be postponed to later in the season. Moderate water deficits at this time can control expansive vegetative growth while allowing photosynthesis to continue unabated (*Figure D-8*). This is the basis for successful deficit irrigation

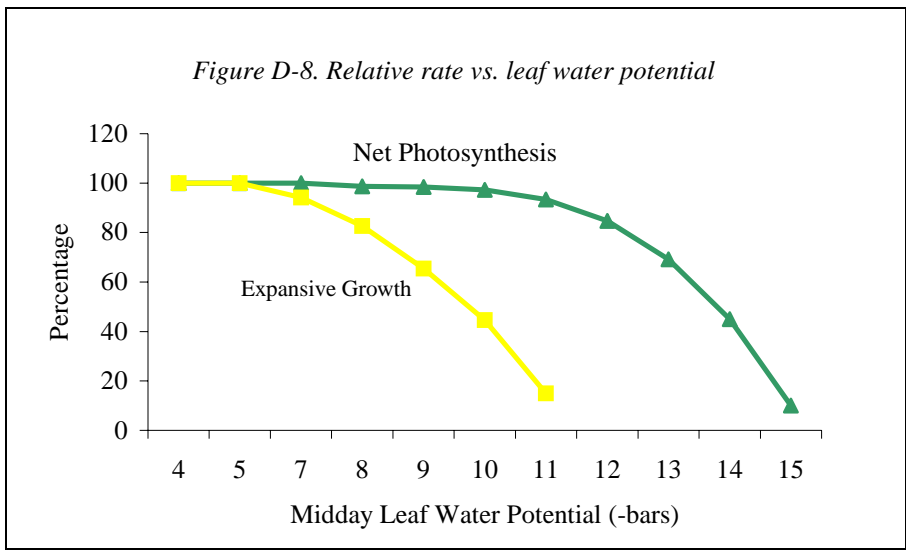

***Post-Veraison Deficits***

Canopy size and climatic conditions drive water use at its maximum rate at this time. Even vineyards with the largest soil resource and cool climate will experience water deficits with out irrigation.

***Postharvest Deficits***

Water deficits at this time do not affect the current year’s crop however severe deficits at this time can lead to low vine carbohydrate reserves to begin the next season. The post harvest root flush period requires soil moisture for the roots to expand. Trunk and root growth is responsive to excess photosynthate after harvest. If vine are defoliated after harvest it is questionable whether to apply water and re-leaf the vine.

## E. Developing a Deficit Irrigation Strategy

### *Regulated Deficit Irrigation*

Regulated deficit irrigation (RDI) is a term for the practice of regulating or restricting the application of irrigation water causing the vine water use to be below that of a fully watered vine. By restricting irrigation water volumes, soil water available to the vine becomes limited to a level where the vine cannot sustain the full potential water use. It is at this point that the vine begins to undergo a water deficit. RDI can be a consistent reduction (i.e., consistent reduction of planned irrigation volumes over the entire season) or the reduction can vary over the irrigation season to induce the desired vine response at the appropriate time.

Figure E-1 shows weekly water use for the unrestricted full potential vine water use and the water use of the a deficit irrigation treatment, which produced the best yield/quality relationship in a mature Cabernet Sauvignon vineyard in Lodi, California over five seasons. The upper line represents the full potential water use of a mature vineyard. It is the volume of water consumed by the vineyard that occurs under conditions where soil water availability is not limited and canopy size shades near 50% of the land surface at midday measured at maximum canopy expansion. About 30% less water was consumed by the deficit irrigation regime on a seasonal basis.

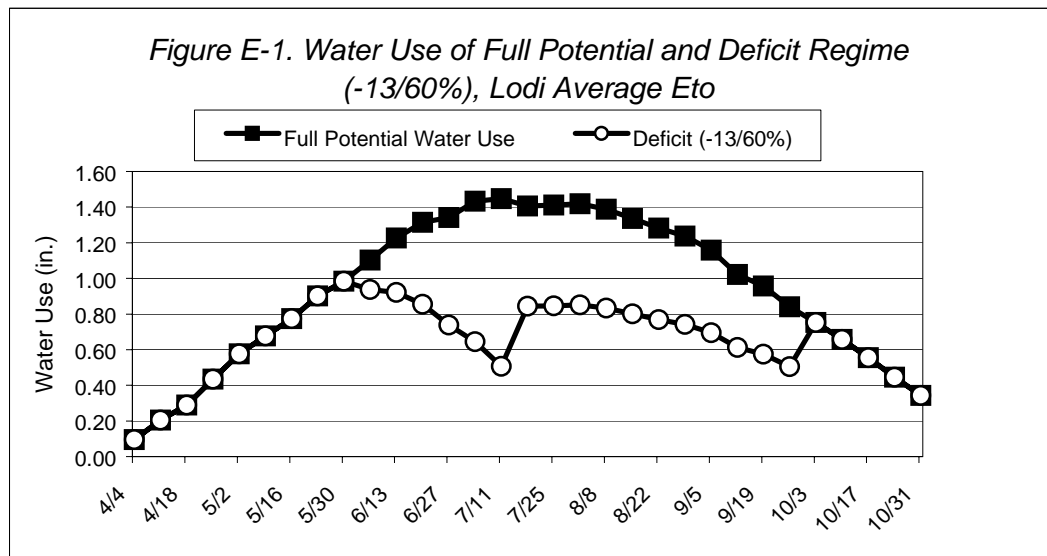

## ***Deficit Threshold Irrigation***

The Deficit Threshold Method (DTI) relies on a predetermined level of midday water deficit (the threshold) to begin irrigation. After the threshold is reached, a reduced water regime is used based on a portion (RDI %) of full potential vine water use. The goal of the Deficit Threshold Method combined with post threshold Regulated Deficit is to improve fruit quality and minimize yield reductions. As shown in *Figure E-1* water is withheld until -13 bars MDLWP when irrigation commenced on July 11.

This method requires measurements of vine water status. The measurement device is called a pressure chamber often referred to as a pressure bomb. To measure vine leaf water status, a leaf is removed from the vine at midday and placed in the chamber with the petiole through a silicone grommet exposed to the atmosphere. In order to reduce the loss of water from the leaf while making the measurement, the leaf is covered with a plastic bag just prior to removing the leaf from the vine. Pressure is applied inside the chamber until the sap exudes from the petiole. The pressure required to exude the sap is an indication of the level of vine water stress. A measurement made in this fashion is called mid-day leaf water potential (MDLWP).

### ***Experiences with Deficit Threshold Irrigation***

Relying on previous experience gained from the irrigation trials referred to above and work of others, it was thought a midday leaf water potential threshold of -13 to -15 bars was a reasonable place to start.

To establish reasonable RDI values, we again reviewed the trial irrigation volumes to see what percentage of full potential water use after irrigation began produced the “best option.” An experimental range was selected of 35 to 60 percent of full potential water use after the threshold was reached. On a seasonal basis, *Figure E-2* shows the typical water sources and amounts consumed for the treatments described in *Table E-1* for cabernet Sauvignon in the North coast in 1999.

Treatment Number	Leaf Water Potential Trigger at Which Irrigation Will Begin	Criteria for Subsequent Irrigation (RDI%)
1	no trigger <-10 bars	supply full water
2	-12 bars	supply 60% of daily full water use
3	-12 bars	supply 35% of daily full water use
4	-14 bars	supply 60% of daily full water use
5	-14 bars	supply 35% of daily full water use
6	-12 bars	supply 35-60% (variable) of daily full water use

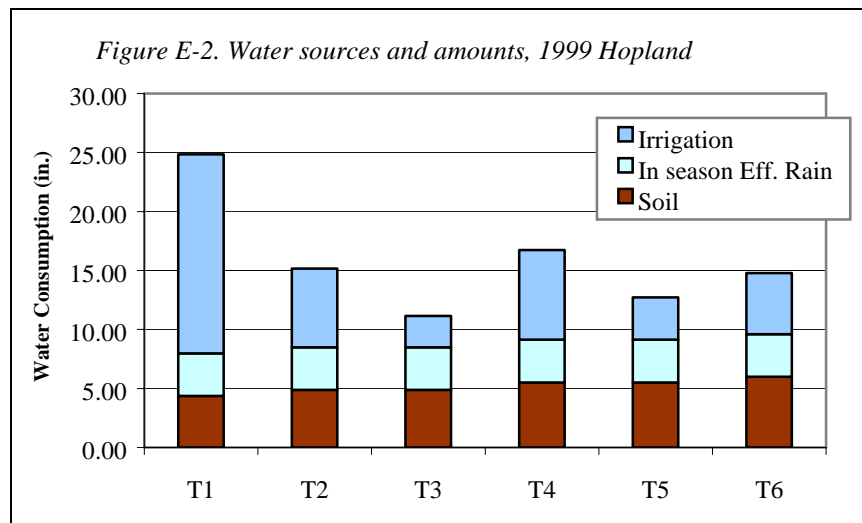

Experiments of these types were conducted in the Lodi area and North Coast working with Merlot, Cabernet Sauvignon and Zinfandel. Results generally support the -12 bar threshold and 60% post threshold RDI % as successful but conservative. Vigorous vineyards may not be adequately controlled using this conservative threshold and RDI. The effect of both threshold and RDI% is more complex incorporating vine balance, fruit light conditions, and wine character and color. Additionally, the qualities sought after in white varieties support these conservative -12/60% RDI strategies. The qualities sought after in white varieties support these conservative -12/60% RDI strategies. Whereas red varieties, where wine color (phenolics) and character (tannins) are more important, support the more stressed thresholds and lower RDI percent. Even within the red grape varieties differences exist in the response to deficits. Merlot is relatively sensitive while Cabernet Sauvignon and Zinfandel are quite tolerant and produce wines with increased character under more water stress.

The Deficit Threshold Irrigation method is easier to implement, requiring fewer measurements and fewer variables than soil based or volume balance methods and seems to work well in moderate to cool climate regions.

## ***Selecting an Appropriate Deficit Threshold and RDI***

Deficit irrigation is not applicable for all vineyards. Young developing vineyards require adequate soil moisture to develop rapid vine structure. Generally deficit irrigation is not practiced until the vineyard is fully developed, usually taking four years or more. Low-vigor vineyards are also not candidates for deficit irrigation as a reduction in vegetative growth is the primary effect of deficit irrigation. Low vigor can occur from pests and diseases as well as nutrient deficiencies and other soil limitations.

All soils and waters contain salts. Some waters are high in salts due to their origin such as groundwater from sediments in coastal ranges of California. Waters originally low in salts can increase as they are used and reused as a consequence of runoff and drainage. Likewise, soils reflect the parent material from which they were developed. Soils which develop from sediments of the ocean floor (coastal and the west side of the valley) tend to be natively high in salts. Soils

of east side of the valley are of granitic origin and tend to be low in salts. Soils also accumulate salts from irrigation waters. Even waters relatively low in salts will eventually salt up soils if the salts are not leached out. Leaching can be accomplished by adequate winter rainfall or by excessive irrigation during the season or off season. During season excess irrigation runs counter to deficit irrigation practices. Therefore, if winter rains are not adequate to keep the root zone salts at a level which will not cause damage, off season leaching is the only option.

### ***Selecting a Deficit Threshold***

The appropriate Deficit Threshold can be determined through experimentation or experience gained by selecting a relatively safe threshold and observing the results then making adjustments for the next season based on the results. There is an emerging consensus that the severity of the deficit threshold is less important than when the deficits begin to effect vegetative growth. It is known that red varieties are more tolerant of increased deficits and tend to have improved fruit qualities when compared to white grapes.

Experimentation in the Southern Sacramento Valley and in the North Coast indicates the -12 to -15 bars is a reasonable deficit threshold however there are factors which should influence your decision.

Red grapes tolerate and benefit more from a more negative threshold. White and sparkling varieties tend to develop more tannins and more color, which may not be desirable favoring a less negative threshold. Red varieties such as Zinfandel usually benefit from a more negative threshold from a character and bunch rot perspective, Cabernet Sauvignon likewise from a character perspective. Merlot is more sensitive and benefits from a less negative threshold.

Vines in deep soil and high total water holding capacity soils located in a cool may not reach the predetermined threshold by harvest or the threshold may be reached only after a sustained severe climate period. In these cases the soil/water resource is just too large for the environmental demand. The use of a cover crop to extract moisture might be appropriate to reduce the available soil water. In shallow soils, low water holding capacity soils the threshold may be reached too early in the season causing water deficits in berry development Stage I. Water deficits at this time will cause smaller berries, which will reduce yields. To avoid this situation irrigation can forestall the reaching of the threshold until the appropriate time.

Rootstock differences seem to make no difference in the threshold selected; however, the rate at which the threshold is reached seems to be rootstock dependent. The more vigorous and root extensive rootstocks will be slower and more predictable in the increase in water stress as they approach the threshold. Less vigorous rootstocks and those that have a predominance of shallow roots will increase in water stress in a more rapid fashion especially when climatic conditions are harsher.

### ***Selecting a Post Threshold RDI%***

An RDI should be selected to ensure continued photosynthesis, adequate fruit cover to protect from heat and sunburn, and to prevent new vegetative growth.

Trials have been conducted using post threshold regulated deficits (RDI) of 35% and 60% of full potential water use. Varieties include Zinfandel, Cabernet Sauvignon and Merlot on Freedom and 5C rootstocks. Generally, the RDI 35% leads to increased levels of water stress from the threshold level to harvest. The length of time from the threshold to harvest determines the ultimate level of stress using the RDI 35%. *Figure E-3* shows the results of four treatments, two thresholds (-12 and -14) at two RDI percentages. They are denoted as 12/60 and 12/35 with the threshold RDI. Included for comparison is the full potential water treatment. Also included is a treatment, which its RDI received 35% for one half the period from the threshold to harvest, then the RDI was increased to 60%. Generally, the leaf water potential remains at or near the threshold if the RDI% is near 60%. At an RDI of 35%, the stress increases towards harvest. The result of too little water towards harvest can be delayed maturity (sugar accumulation), loss of fruit leaf cover and lower berry size.

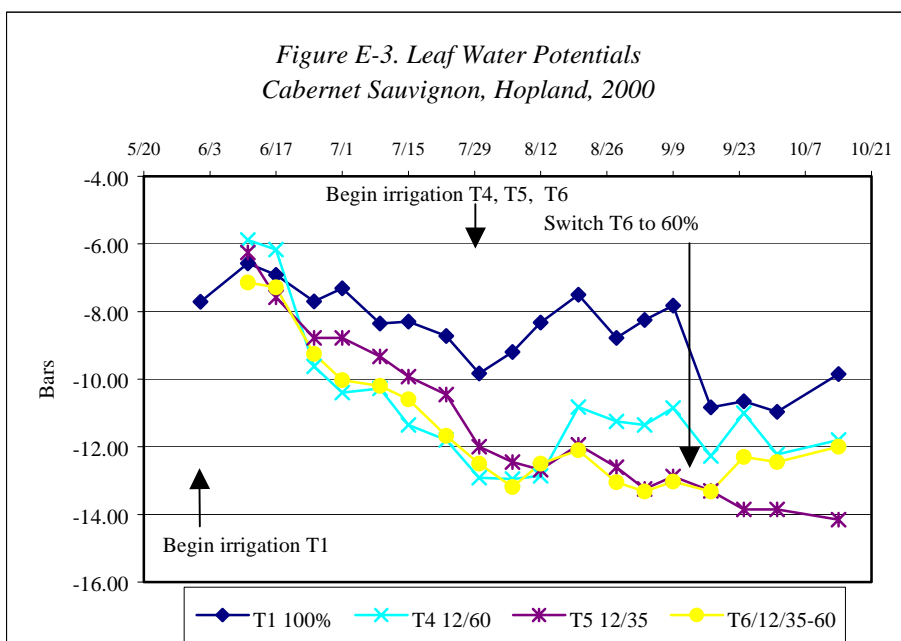

## F. Methods for Determining When to Begin Irrigation

The decision of when to irrigate encompasses the desire to produce a specific quality crop and the soil resource and climate in a specific year. If winter rainfall is inadequate to fill the soil storage capacity to a normal season level one might irrigate to bring the soil to a normal bud break level. This practice should bring about normal or adequate shoot growth. If the vineyard normally has excessive shoot growth this may be an opportunity to reduce shoot growth by not adding irrigation water.

Once the season begins and shoot growth progresses the decision of when to begin irrigation depends on the level of water stress the vine experiences and how that relates to your overall strategy to produce quality fruit. This strategy includes the level of stress at which you plan to irrigate. There are a number of visual and measured indicators of water stress. In a Cabernet Sauvignon trial located in Hopland, California, a number of visual and measured indicators were evaluated. Treatments are explained in *Figure E-1*.

### *Visual and Measurements*

#### *Shoot length*

Many of the symptoms of water deficits are visual and therefore can be observed or easily measured. However, for a method to be used to determine when to begin irrigation, it must not only be easy to use but also reliable. It should be able to predict a certain level of water deficits each season. A number of these indicators have been proposed and are in use to determine when to begin irrigation. They include shoot length, shoot growth rate, and tip ratings. Measurement of plant water status through direct methods using a pressure chamber and indirect methods using infrared devices to measure canopy temperature are also in use.

### *Shoot Growth*

Shoot lengths are influenced by water deficits if the deficits occur soon enough to slow shoot growth more than the normal slowing as veraison is approached. *Figure F-1* shows shoot growth of the Cabernet Sauvignon vineyard near Hopland, California, for the 1999 season. The full irrigation (T1) began receiving irrigation June 1 while treatments 4 and 6 began on July 16th at  $-12$  bars. All non-irrigated treatments had stopped growing by July 9. Even with irrigation, the growth slows with time. It appears that shoot length is a better indicator of the seasonal strategy rather than an indicator of when to begin irrigation.

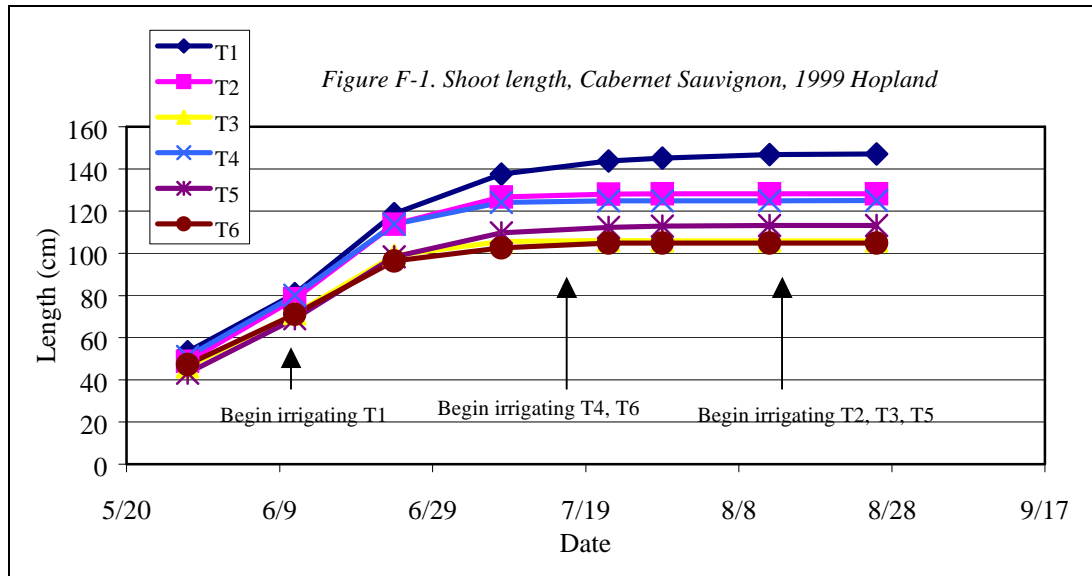

### Shoot Growth Rate

**Shoot Growth Rate**

Shoot growth rate begins after bud break and increases with time to a maximum usually in mid-June then decline rapidly to near zero within about 30 days (*Figure F-2*). Shoot growth was about 0.75 cm/day when treatments 4 and 6 reached the  $-12$  bars mid-day leaf water potential. Treatment 5 reached  $-12$  bars after all growth had stopped on August 13<sup>th</sup>. In the year 2000 in the same trial,  $-12$  bars level was reached at 0.2 cm/day growth rate. Based on the results, it seems the slowing of growth rate varies as does midday leaf water potential, (and therefore water deficits), but is not strongly related.

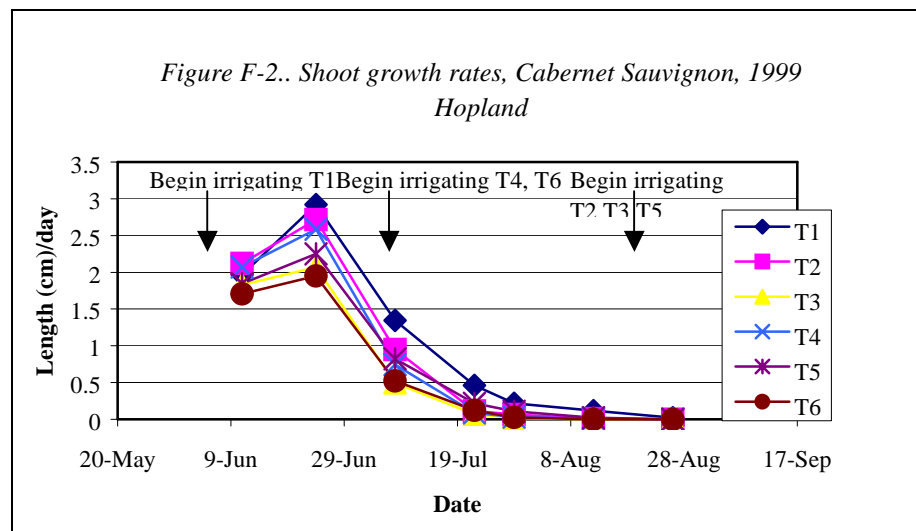

### Tip Ratings

**Shoot Tip Condition Rating**

Another indicator used to determine when to begin irrigation is shoot tip condition. A

rating system has been devised using numbers 1-6. A rating of 1 is when the tendril extends past the tip. A rating of 2 is when the tendril is equal to the tip; a 3 rating is when tendril is behind the tip. A 4 rating is tendril yellow, a 5 rating when there is no tendril present, and a 6 rating when the tip growing point is dead. The array of tip conditions in the vineyard is great. Often tips will span a rating of 3 levels. It is a challenge to obtain a representative value.

Figure F-3 shows the tip ratings for the 1999 Hopland trial. All readings prior to July 22 were from 1 to 1.5 and not significantly different between treatment and dates. The July 22 readings increased to an average of 2.7 with no significant difference between treatments including the T1, which had been receiving water since June 1<sup>st</sup>. On July 29<sup>th</sup>, the average had increased to 3.6 with no significant differences between the treatments irrigated on July 16th (T4 and 6) and those not yet irrigated (T2, 3, and 5). On August 12, the average of all yet to be irrigated treatments (T2, 3 and 5) was 5.4 which not significantly different from those irrigated four weeks earlier. Tip ratings do not seem to be responsive to irrigation unless it begins early in the season,. Based on the results, shoot tip ratings increase in a linear fashion once shoot growth declines

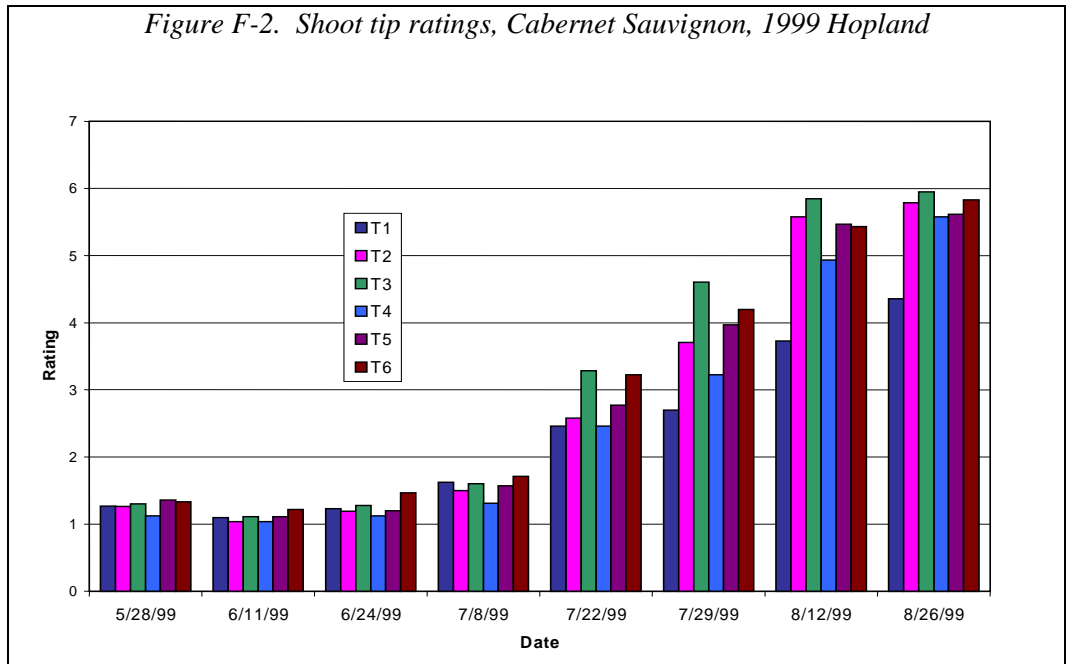

**Midday Leaf  
Water Potential**

Water is pulled from the soil up through the plant by forces driven by water loss from the leaves. Water within the plant mainly moves through very small-interconnected cells, collectively called xylem, which are essentially a network of pipes carrying water from the roots to the leaves. The water in the xylem is under tension, and as the soil dries, or for if some other reason the roots become unable to keep pace with the evaporative demand from the leaves, the tension increases. Under these conditions, the vine experiences a water deficit.

The pressure chamber (often called a pressure bomb) is a device for applying gas pressure to a leaf where most of the leaf is inside the chamber but a small part of the leaf stem (the petiole) is exposed to the outside of the chamber through a seal (Figure F-4). The amount of pressure that it

takes to cause water to appear at the end of petiole indicates the level of tension the leaf is experiencing. A high pressure means a high amount of tension and a high degree of water stress. The units of pressure most commonly used are the Bar (1 Bar = 14.5 pounds per square inch) and the Mega Pascal (1 MPa = 10 Bars).

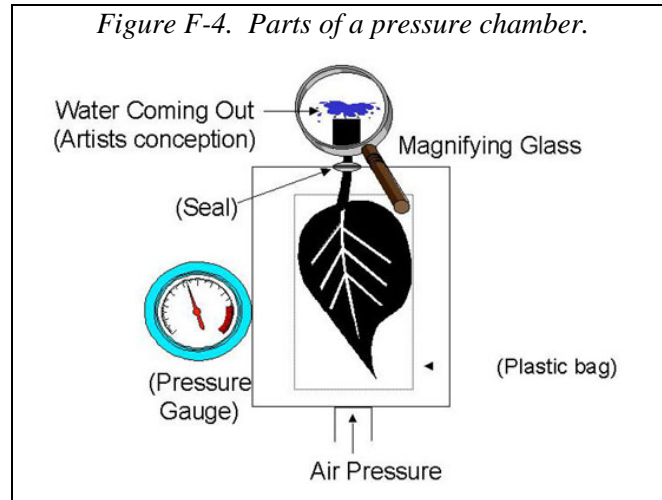

Courtesy of PMS Instruments

The pressure chamber measures water potential using a positive pressure to overcome the force (tension) under which the water is held in the leaf. The tension is therefore expressed as a negative number. Typical mid season reading for a well-watered vine would be more than (less negative)-9 bars. The physics of how the water moves from the leaf to the atmosphere is more complex than just "squeezing" water out of a leaf, or just bringing water back to where it was when the leaf was cut. However in practice, it is only important for the operator to recognize when water just begins to appear at the cut end of the petiole and note the pressure required.

Midday leaf water potential was measured weekly after June 1 (*Figure F-5*) in the Hopland trial. The full potential water use treatment (T1) maintained an average of more than -10 bars for the entire season. The all the other not yet irrigated treatments increased in water stress until irrigation was applied. In the case of treatment 4 was irrigated at a threshold of -12 bars whereas treatment 2 was irrigated at -14 bars. The use of the pressure chamber to measure mid-day leaf water potential appears to be an accurate and reliable method used as an indicator of when to begin irrigation.

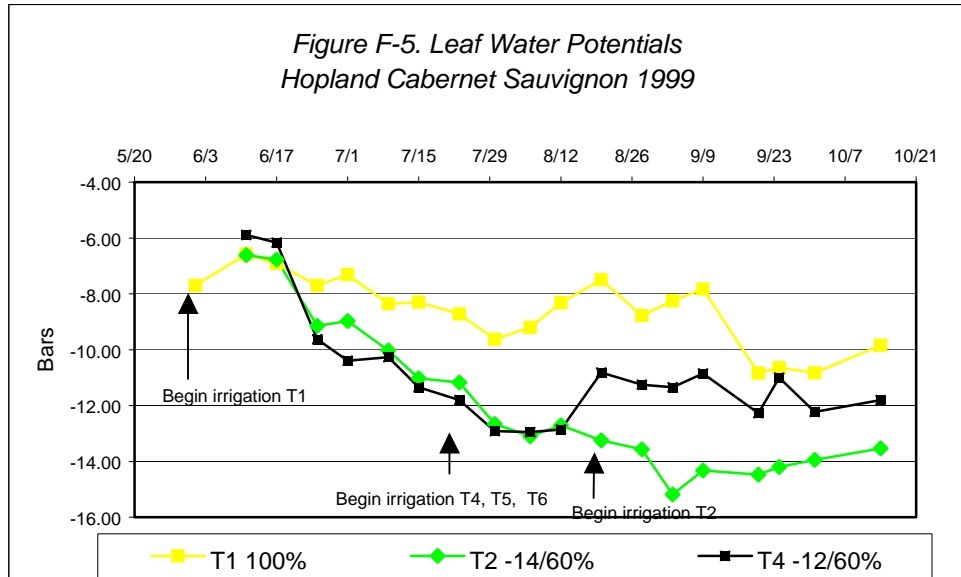

### *Using the Pressure Chamber in Winegrape Irrigation Scheduling*

The pressure chamber can be used to measure the severity of water deficits throughout the season. Water deficits are commonly used in the culture of winegrapes to produce desirable fruit quality. Using the pressure chamber to measure leaf water potential is a key step in determining when to begin irrigation. The pressure chamber can also be used to monitor the vine water status after irrigation begins.

### *When to Sample*

The loss of water from the leaf is not constant throughout the day and varies with a number of factors including the environmental demand. This factor can be minimized however by measuring when the leaf water potential is relative static. Before the sun reaches the leaf in the morning, the vine has had a chance to uptake water and translocates it to all parts of the plant relieving to some degree the previous day's deficit. The leaf water potential is the least negative at this time for the day. As the sun contacts the leaf and heats the surface, the rate of transpiration increases, causing a more negative leaf water status. During the midday (solar noon), the water potential is again static at the daily maximum deficit (*Figure F-6*).

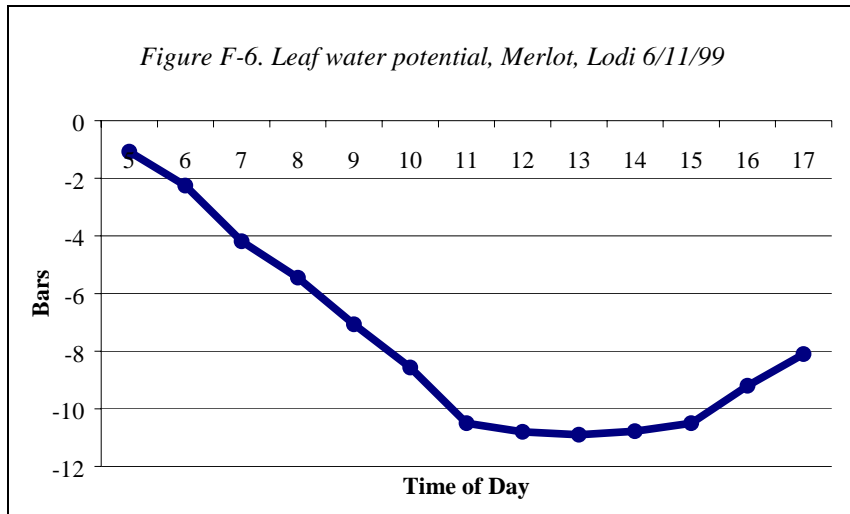

### ***Factors that Influence Leaf Water Potential***

The most important factors are:

- weather conditions at the time of sampling, and
- soil dryness

For fully irrigated vines with a healthy root system, weather conditions can have a large impact. *Table F-1* lists the effect of air temperature and relative humidity on fully watered prunus species. In all cases, hotter and dryer conditions cause a more negative water potential. For midsummer conditions in California, the values of water potential measured on a fully irrigated grapevine will typically be between -7.0 bars and -10.0 bars. To minimize the effect of temperature, measurements should be taken only when average conditions exist. For example: If average midday temperatures are 92°F., measurements can be made on days with midday temperatures of 90 to 95° with no need to make an adjustment for climate. The same case can be made for low or high humidity days. Cloudy or foggy days or days with high winds should be avoided. The level of water stress as gauged by the mid-day leaf water potential can be generalized as shown in *Table F-2*.

*Table F-1. Values of midday stem water potential (in Bars) to expect for fully irrigated prune vines, under different conditions of air temperature and relative humidity. (from Ken. Shackel)*

Temperature (°F)	Air Relative Humidity (RH, %)						
	10	20	30	40	50	60	70
70	-6.8	-6.5	-6.2	-5.9	-5.6	-5.3	-5.0
75	-7.3	-7.0	-6.6	-6.2	-5.9	-5.5	-5.2
80	-7.9	-7.5	-7.0	-6.6	-6.2	-5.8	-5.4
85	-8.5	-8.1	-7.6	-7.1	-6.6	-6.1	-5.6
90	-9.3	-8.7	-8.2	-7.6	-7.0	-6.4	-5.8
95	-10.2	-9.5	-8.8	-8.2	-7.5	-6.8	-6.1
100	-11.2	-10.4	-9.6	-8.8	-8.0	-7.2	-6.5
105	-12.3	-11.4	-10.5	-9.6	-8.7	-7.8	-6.8
110	-13.6	-12.6	-11.5	-10.4	-9.4	-8.3	-7.3
115	-15.1	-13.9	-12.6	-11.4	-10.2	-9.0	-7.8

*Table F-2. Levels of winegrape water deficits measured by mid-day leaf water potential*

1	less than -10 Bars	no stress
2	-10 to -12 Bars	mild stress
3	-12 to -14 Bars	moderate stress
4	-14 to -16 Bars	high stress
5	above -16 Bars	severe stress

The relationship of soil dryness to water potential is straightforward: as the soil becomes dryer, water potential will become more negative given static climatic conditions. The pressure chamber measures effective soil dryness throughout the root system as a whole. This is very different from soil-based monitoring methods, which only measure the soil in part of the root zone.

### ***Operation and Use of the Pressure Chamber***

The leaf should be covered to prevent water loss just before removal from the plant. This practice minimizes water loss from the leaf. A small thin sandwich bag is most commonly used. The use of a bag reduces the loss of moisture from the leaf and lessens the need to complete the measurement quickly, thereby making measurements more consistent.

### ***Vine Selection***

It is important to select vines for measurement that represent the average vine condition. Select those that do not have obvious nutritional, disease or other visual problems. All vineyards are variable in terms of soil uniformity. If distinct differences in soil

type/depth occur in the vineyard, select vines in each area or block to monitor differences. Mark vines so the same vines can be measured each sampling.

### ***Sample Number***

The number of vines, measured depends somewhat on the variability of the vineyard; however it is necessary to measure enough leaves to closely approximate the average condition. For a 20-acre vineyard, selection of six vines located in all parts of the vineyard should be adequate. Select two leaves per vine for measurement.

### ***Leaf Selection***

Select a young fully expanded leaf that has been in full sun for a few hours from the sun side of the vine. This will be the south side of east-west rows and the west side of north-south rows. Leaves in the interior of the canopies, which are shaded, will not accurately represent the maximum leaf water potential and should be avoided. Young leaves, which have not achieved full size, should also be avoided.

### ***Sample Collection***

It is most convenient to cover the leaf with a plastic sandwich bag then pick the leaf from the plant by gently snapping the leaf off at its connection to the shoot. Place the leaf into the flexible grommet in the pressure chamber gland and tighten only till enough resistance is felt to hold the petiole. Place the bagged leaf into the chamber and lock the lid in place. Re-cut the leaf petiole to a flat surface with a sharp razor. The time from leaf collection and tension measurement should be small delays will lead to erroneous values.

### ***Measurement***

With the leaf inside the chamber, the measurement is made by simply increasing the pressure in the chamber until water begins to come out of the xylem that is exposed at the petiole cut surface. Usually, the pressure at which sap appears is very. Using a hand lens, the water coming out of the petiole cut surface will glisten then as pressure increases it looks like an up welling of water from a porous surface.

The rate of pressure increase should be no more than 0.3 bars per second (Naor and Peres, 2001). A leaf with a reading of  $-10$  bars would take a minimum of 30 seconds. Additionally, a fast rate of pressurization can cause an over estimation of water potential due to the time taken to stop the pressurization or read the gauge. If you overshoot, nearly the same value can be obtained if you re-measure the same leaf. You should also get nearly the same value (typically within 0.5 bar) when you measure adjacent leaves on the same shoot. Taking multiple reading on the same vine is a good way to check your reproducibility or compare the effects of different operators or techniques. The practice of rapidly increasing pressure to near the expected reading, then increasing the pressure slowly to the end point is discouraged due to unacceptably high error.

## ***Problems***

There are two common problems that can make the endpoint difficult to detect: bubbling and the appearance of non-xylem water. If there are breaks in the leaf inside the chamber, then air can be forced through the xylem and come out of the cut end. If this air pushes some water out, or if there is a little fluid from the cells at the cut surface, then the air coming out can bubble through the water, and it can look like there is water coming out when in fact it is just the same water being bubbled around. Discard the leaf and select another sample.

Non-xylem water can occur when you squeeze the petiole in the seal and water is physically squeezed out the cut end. If you think it is the endpoint, note the pressure, then dry off the cut end and raise the pressure a bit. If more water comes out of the cut surface, then it probably was the endpoint, but if it remains dry, then it probably was non-xylem water. If in doubt sample another leaf.

## ***Reproducibility***

Two or more leaves on the same vine should give almost identical readings, i.e., within about 0.5 bars. It is good practice for beginners to sample more than one leaf per vine to check for reproducibility of measurement. With experience, only one leaf per vine is necessary. You should also get nearly the same value if you re-measure the same leaf. This is done once you see the first endpoint by reducing the pressure enough that water disappears into the petiole, and then increasing the pressure until you see the endpoint again. Different vines can give different readings, however, and these will reflect real differences in water potential, so it is important to keep track of each vine separately.

## G. Developing the Irrigation Schedule

### *Defining Mature Vineyard/Site Conditions*

The first step in developing an irrigation schedule is to quantify both the vineyardist and winemaker's goals for the variety and style of wine. This is necessary to develop a strategy using canopy, crop, and irrigation management to achieve the set goals. From this point, vineyard conditions and the irrigation system capabilities can be used to develop an irrigation schedule that will implement the strategy. The following is a list of the necessary vineyard/irrigation/strategy information needed to develop the schedule along with a scenario to develop a deficit irrigation schedule.

Variety/rootstock	Cabernet Sauvignon/Freedom
Site	Lodi, CA
Soil	Sandy loam
Root zone	8 feet depth
Root zone total soil moisture, bud break	16.0 inches
Root zone soil moisture, threshold	12.5 inches
Root zone soil moisture, harvest (previous year)	10.0 inches
Vine spacing	7 × 11 feet
Canopy (trellis)	Bilateral cordon w/ T top
Land surface shaded	40 %
Covercrop	None
Irrigation system	Drip
Emitter flow rate	1.0 gal/hr
Emitter per vine	1
Harvest date (est.)	10/1
Deficit Threshold	-13 bars
Regulated deficit (RDI %)	50 %
Threshold date	July 16 <sup>th</sup>
Post harvest irrigation	One month estimated full potential water use (Oct)

Calculated values based on above information:

Vines per acre	566
Sq ft per vine	77
Gross application rate	0.021 in/hr
Soil available water (bud break)	6.0 in.
Soil Available water (threshold)	2.5 in.

# Determining How Much to Apply

## Estimating Full Potential Water Use

The full potential water use varies as a result of climatic conditions and the size of the canopy. The climate factor can be estimated using the reference evapotranspiration (ET<sub>o</sub>) values, which by itself indicates vine water use will vary over the season (*Figure G-1*). Normal or average year's data (1984- 2003) is shown for Lodi, California. Water use is also influenced by vine canopy growth from bud break to full canopy expansion. Canopy growth is accounted for by a modifying factor of the ET<sub>o</sub> called the Crop Coefficient (K<sub>c</sub>) (*Figure G-2*). The K<sub>c</sub>, which varies from a small value after bud break and increases as the vine canopy expands to maximum size. Together, these factors (ET<sub>o</sub> × K<sub>c</sub>) contribute to a water use pattern that begins at a low rate in spring, peaks in mid-summer, and then declines as leaf drop approaches (*Figure G-3*). Canopy management practices such as hedging or canopy disruption by machine harvesting can further modify this pattern by reducing the energy interception of the vine and therefore the K<sub>c</sub>. When considering the water use of a single vine, a larger canopy will have a larger leaf area exposed to the atmospheric conditions that drive water use and, therefore, that individual vine will have a greater water use.

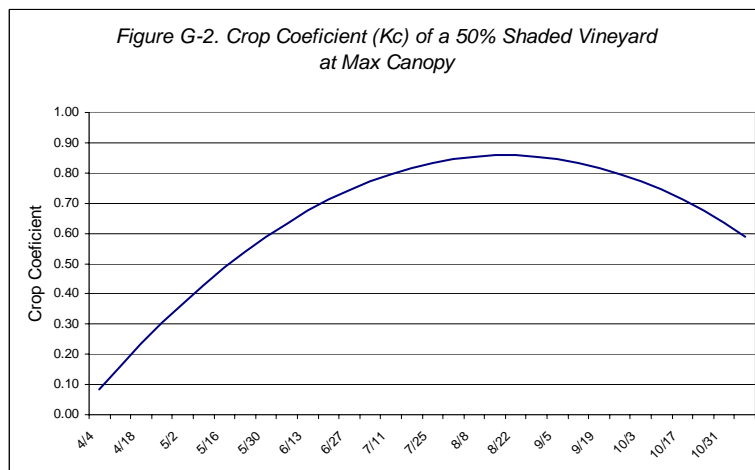
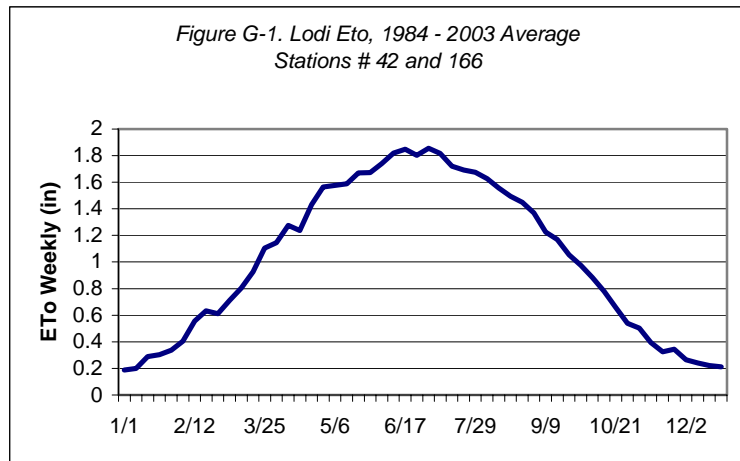

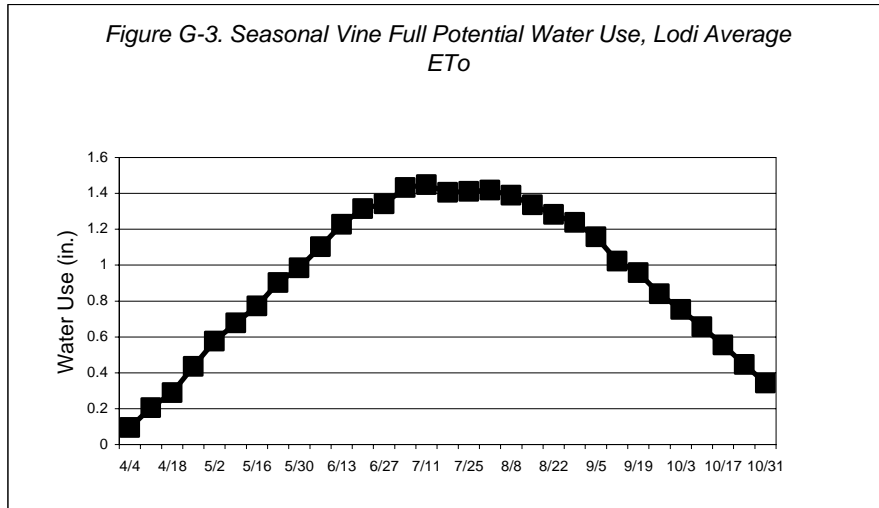

When estimating the water use of an area of land planted to winegrapes (ETc), it is necessary to quantify the extent of canopy coverage by measuring the percentage of land surface shaded by the vine canopy. Row spacing can have a significant influence on percent land surface shaded since with a given trellis and canopy size a closer row spacing increases the percent land surface shading. In addition, trellis design, vine health, and vigor as a result of rootstock/scion combination, soil conditions, pests, and fertilization can affect the land surface shaded. Vine training, trellis type, and spring growth conditions can influence the rate of canopy expansion and, therefore, the land surface shaded at any point in time. These variables that contribute to land surface shading can significantly affect vine water use

The percentage of land surface shaded is measured midday (solar noon). Vine water use increases as the percent of land surface shaded increases. The practical ramifications are that wider spaced rows, young winegrapes or low vigor vines with a small canopy have a lesser percentage land surface shaded and use less water on a per- acre basis than vines with a larger coverage canopy.

The method described in the next section for estimating land surface shading seems to work well with bilateral or quadrilateral trellis systems, but less so when vertical shoot positioning (VSP) vineyards are measured. VSP canopies have the minimum land surface shaded at solar noon when row orientation is north/south and therefore may require a different method to account for the canopy/land surface relationship. Research is currently underway to develop a reliable method for use with VSP and similar trellis systems.

Generally, a canopy which establishes at a faster rate, i.e., cane-pruned or a quadrilateral system, increases early water use (at a faster rate) and can, at full expansion, have a larger percent land surface coverage. *Figure G-3* illustrates the weekly use over the season and *Figure G-4* the seasonal cumulative water use of a vineyard in the Lodi area with 50 percent land surface shading at maximum canopy expansion and adequate soil moisture for the entire season.

Evapotranspiration Reference  $\times$  Crop Coefficient = Evapotranspiration of the Crop

$$ET_o \times K_c = ET_c$$

If water availability is not limiting,  $ET_c$  is full potential water use

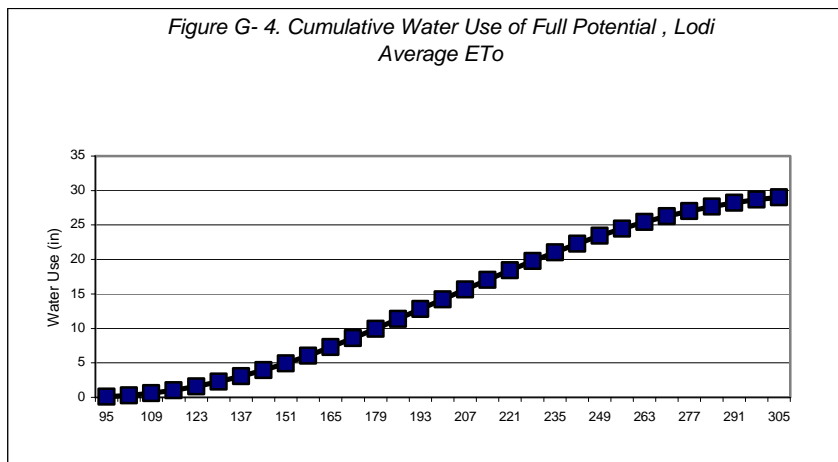

### ***Evapotranspiration Reference Values ( $ET_o$ )***

Evapotranspiration Reference Values ( $ET_o$ ) are calculated using measurements of climatic variables including solar radiation, humidity, temperature, and wind speed and expressed in inches or millimeters of water. A one-inch depth of water use, like rainfall or irrigation water, is equal to 27,158 gallons per acre of land.  $ET_o$  values most closely approximate the water use of a short mowed full coverage grass crop. Climatic conditions are constantly collected from which  $ET_o$  values are calculated and made available by the CIMIS Program. The California Irrigation Management Information System (CIMIS) is managed by the State of California Department of Water Resources, which collects, maintains and supplies Reference Evapotranspiration ( $ET_o$ ) values from nearly 100 weather stations throughout California. Both historical averages (normal) and real time (current year) values are available. CIMIS is on the web at: <http://www.cimis.water.ca.gov>

### ***Crop Coefficient ( $K_c$ )***

The Crop Coefficient ( $K_c$ ) is a factor, which allows the use of Reference values ( $ET_o$ ) to estimate winegrape water use ( $ET_c$ ) of a non-water stressed vineyard.  $K_c$  values have been experimentally linked to the percent shaded area in the vineyard measured at midday. They can be measured at any time of the season, however when using the Deficit Threshold Method, it is necessary to only measure at the threshold or beginning of the irrigation. At that time, canopy expansion is complete. It should be re-measured if canopy reductions occur due to canopy management such as hedging.

Larry Williams demonstrated in a weighing lysimeter at the Kearney Ag Station that vineyard water use increases linearly with the percentage of land surface shaded by the crop (Figure G-5). He suggests measuring the percent shaded at midday and using the relationship to determine the Kc. The equation to describe the relationship between the crop coefficient Kc and percent shaded area is:

$Kc = 0.002 + 0.017 \times \text{the percent shaded area}$ <p>Simplified Equation:</p> $Kc = 1.7 \times \text{percent shaded area (ie., 0.40 or 40\%)}$
---------------------------------------------------------------------------------------------------------------------------------------------------------

The procedure would entail measuring the average shade on the floor at mid-day of (as an example above), a 11-foot row spacing with a 7 foot vine spacing. The average amount of shade between two vines is measured at 31 sq ft compared to the vine spacing of 77 or 40% of the square foot area of one vine. The Kc is calculated as follows:

$$Kc = (0.40 \times 1.7) = 0.68$$

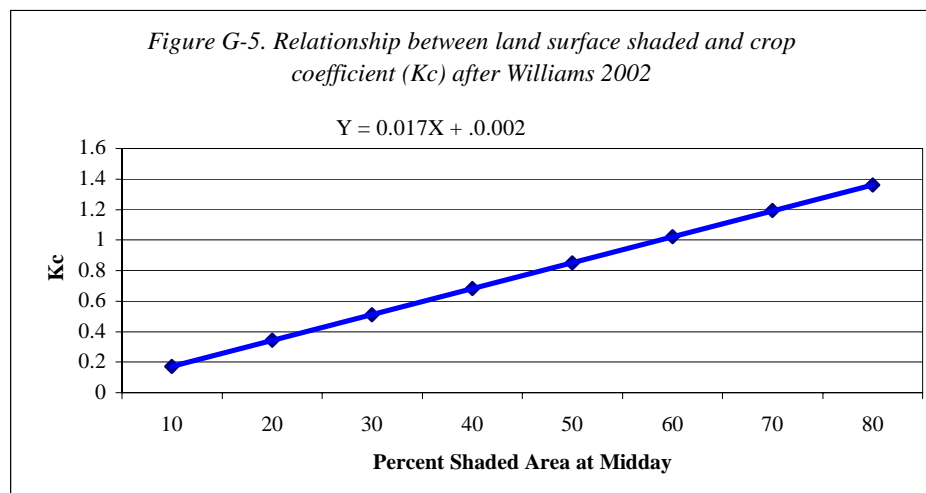

### ***Calculating Full Potential Water Use with Historical Average Eto***

After the -13 bar threshold was achieved (July 8 in this example), the net irrigation requirement can be calculated from the threshold date to the end of the season using average historical ETo values. The product of ETo and Kc yields the full potential water use.

$$ETo \times Kc = \text{Full Potential Water Use (ETc)}.$$

Figure G-1 shows an example calculation of weekly full potential water use for Lodi, CA using the 1984 to 2003 historical average ETo for CIMIS stations #42 and #166. The Kc used is 0.68 which developed above for a 40% midday shaded

area. Calculations are made only after the threshold MDLWP (-13 bars) was measured in the vineyard on July 8.

*Figure G-6. Irrigation Scheduling Worksheet - Lodi, CA*

ETo are the averages of daily data from 1984 to 2003.  
from the Lodi (CIMIS #42) and West Lodi (#166) weather stations

Assumptions  
1. Leaf Water Potential trigger was reached July 8th.  
2. Harvest Date was October 1.

Date	A = Historical Eto <sup>a</sup>	B = Crop Coefficient <sup>b</sup>	C = A x B: Potential Water Use
Period	Inches/Period	Kc	(in)
Jly 8-14	1.82	0.68	1.24
Jly 15-21	1.720	0.68	1.17
Jly 22-28	1.692	0.68	1.15
Jly 29 to Aug 4	1.676	0.68	1.14
Aug 5-11	1.626	0.68	1.11
Aug 12-18	1.556	0.68	1.06
Aug 19-25	1.494	0.68	1.02
Aug 26 to Sept 1	1.448	0.68	0.98
Sept 2-8	1.368	0.68	0.93
Sept 9-15	1.225	0.68	0.83
Sept 16-22	1.171	0.68	0.80
Sept 23-29	1.054	0.68	0.72
Sept 30 to Oct 6	0.974	0.68	0.66
Oct 7-13	0.883	0.68	0.60
Oct 14-20	0.779	0.68	0.53
Oct 21-27	0.660	0.68	0.45
Oct 28 to Nov 3	0.540	0.68	0.37
<b>Total</b>			<b>14.75</b>

<sup>a</sup> <http://www.cimis.water.ca.gov/cimis> or <http://ucipm.ucdavis.edu>  
<sup>b</sup> Crop Coefficient calculated based on 40% midday land surface shaded (0.68)

### ***Calculating the Water Use Using the Regulated Deficit % (RDI%)***

Once the full potential water requirement is calculated for the vineyard as in *Figure G-6* the Regulated Deficit percent (RDI %) can be used to calculate the amount of water the vineyard will use under the RDI % you have selected. In our example, 0.50 or 50 % of full potential water use was selected. *Figure G-7* shows the full potential water use (calculated in *Figure G-6*) x RDI% equals the amount of water use for the selected RDI%. Notice the RDI % increased to 1 or 100% after harvest as full water is required to encourage root growth and further carbohydrate accumulation.

**Figure G-7. Irrigation Scheduling Worksheet - Lodi, CA**

ETo are the averages of daily data from 1984 to 2003.  
from the Lodi (CIMIS #42) and West Lodi (#166) weather stations

**Assumptions**

1. Leaf Water Potential trigger was reached July 8th.
2. Harvest Date was October 1.

Date	C = A x B: Potential Water Use	D = RDI coefficient <sup>c</sup>	G = [(C x D) - E - F]: Net Irrigation Requirement
Period	(in)	RDI %	(in)
Jly 8-14	1.24	0.5	0.62
Jly 15-21	1.17	0.5	0.58
Jly 22-28	1.15	0.5	0.58
Jly 29 to Aug 4	1.14	0.5	0.57
Aug 5-11	1.11	0.5	0.55
Aug 12-18	1.06	0.5	0.53
Aug 19-25	1.02	0.5	0.51
Aug 26 to Sept 1	0.98	0.5	0.49
Sept 2-8	0.93	0.5	0.47
Sept 9-15	0.83	0.5	0.42
Sept 16-22	0.80	0.5	0.40
Sept 23-29	0.72	0.5	0.36
Sept 30 to Oct 6	0.66	1	0.66
Oct 7-13	0.60	1	0.60
Oct 14-20	0.53	1	0.53
Oct 21-27	0.45	1	0.45
Oct 28 to Nov 3	0.37	1	0.37
<b>Total</b>	<b>14.75</b>		<b>8.68</b>

<sup>a</sup> <http://www.cimis.water.ca.gov/cimis> or <http://ucipm.ucdavis.edu>

<sup>b</sup> Crop Coefficient calculated based on 40% midday land surface shaded (0.68)

<sup>c</sup> Regulated Deficit is 50% (0.5)

***Accounting for the Soil Contribution and Effective Rainfall.***

The soil moisture content declines as the vine extracts moisture from the beginning of shoot growth until the leaf water potential threshold is reached. The vine can still remove additional moisture from the root zone; however since the available moisture is at deeper depths, the rate of extraction is slow. In order to account for this water input to meet the water volume, we calculated in *Figure G-3* that it is necessary to measure or estimate its volume. In deep (7 ft) medium texture soils, an average amount of water which will be removed by harvest is typically 2½ inches. On shallower soils, this amount can be as low as 1 inch. Using a calibrated instrument which reads in inches of water per foot of soil, the water content of the root zone can be measured (see Section C). Measure at bud break, the threshold and at harvest. These times represent the full point, the threshold and the dry point respectively. Subtracting the threshold content from the bud break content will represent the amount of soil moisture used up until the threshold. Additionally, subtracting the dry point from the threshold count represents the volume of water the vines will use from the threshold through harvest. *Table G-1* shows the readings typical of a 7 ft depth sandy loam soil in Lodi, California. If soil measurements are not available, use the estimations mention above.

<i>Table G-1. Total Root Zone Soil Moisture Content</i>		
Total Moisture	Inches	
A – Bud Break	16.0	
B – Threshold	12.5	
C – Harvest	10.0	
Available Water	Inches	
Bud Break	A – C	6.0
Threshold	B – C	2.5

The water that will be used from the threshold to harvest is called the soil contribution. Divide the amount (in this example, 2.5 inches) by the weekly periods from the threshold to the estimated harvest date, July 8 through Sept 30.

$$2.5 \text{ inches} / 12 \text{ weekly periods} = 0.2 \text{ inches per period}$$

*Figure G-8* illustrates the addition of the estimated soil contribution of each weekly period from the threshold to harvest.

Effective rainfall is usually minimal in the period of time from the threshold through harvest. However, significant rainfall is possible and must be accounted for as a water source to meet the calculated vine requirement. The most practical method to estimate effective in-season rainfall for vineyards is using the formula:

$$\text{Effective Rainfall} = [\text{rainfall (in)} - 0.25 \text{ in}] \times 0.8$$

This method discounts the first 0.25-inch as lost to evaporation after the event and estimates 80% of the remainder is stored in the soil for vine use (see Section C for a detailed discussion).

In the example spreadsheet the effective rainfall is entered the week beginning October 28. The measured rainfall was 0.65 inches. Calculations are as follows:

$$\text{Effective Rainfall} = [0.65 - 0.25] \times 0.8 = 0.32 \text{ in.}$$

Effective rainfall is entered in the spreadsheet in column F on the week beginning October 28 (*Figure G-8*).

Notice that the 0.32 inches is nearly equal to that weeks calculated vine use and the irrigation volume is reduced to near zero for that period.

**Figure G-8. Irrigation Scheduling Worksheet - Lodi, CA**

ETo are the averages of daily data from 1984 to 2003.  
from the Lodi (CIMIS #42) and West Lodi (#166) weather stations

Assumptions  
1. Leaf Water Potential trigger was reached July 8th.  
2. Harvest Date was October 1.

Date	C = A x B: Potential Water Use	D = RDI Coefficient <sup>c</sup>	E = Soil Contribution	F = Effective Rainfall <sup>d</sup>	G = [(C x D) - E - F]: Net Irrigation Requirement
Period	(in)	RDI %	(in)	(in)	(in)
Jly 8-14	1.24	0.5	0.2	0	0.42
Jly 15-21	1.17	0.5	0.2	0	0.38
Jly 22-28	1.15	0.5	0.2	0	0.38
Jly 29 to Aug 4	1.14	0.5	0.2	0	0.37
Aug 5-11	1.11	0.5	0.2	0	0.35
Aug 12-18	1.06	0.5	0.2	0	0.33
Aug 19-25	1.02	0.5	0.2	0	0.31
Aug 26 to Sept 1	0.98	0.5	0.2	0	0.29
Sept 2-8	0.93	0.5	0.2	0	0.27
Sept 9-15	0.83	0.5	0.2	0	0.22
Sept 16-22	0.80	0.5	0.2	0	0.20
Sept 23-29	0.72	0.5	0.2	0	0.16
Sept 30 to Oct 6	0.66	1		0	0.66
Oct 7-13	0.60	1		0	0.60
Oct 14-20	0.53	1		0	0.53
Oct 21-27	0.45	1		0	0.45
Oct 28 to Nov 3	0.37	1		0.32	0.05
<b>Total</b>	<b>14.75</b>		<b>2.40</b>		<b>5.96</b>

<sup>a</sup> <http://www.cimis.water.ca.gov/cimis> or <http://ucipm.ucdavis.edu>  
<sup>b</sup> Crop Coefficient calculated based on 40% midday land surface shaded (0.68)  
<sup>c</sup> Regulated Deficit is 50% (0.5)  
<sup>d</sup> Effective rainfall is calculated from actual rainfall.  
Calculations are not shown on this sheet.

## Determining the Weekly Vine Irrigation Volume

Irrigation systems, including brand new systems, do not apply water evenly to the entire vineyard. This is known as uniformity. When practicing deficit irrigation, generally no runoff or deep percolation losses occur; however, variation in the flow of the emitters (called manufacture's coefficient of variation) can account for 5% of the variation. Other causes of non-uniformity include pressure variations in the system and emitter clogging. A method to determine the emission uniformity and the average emitter discharge in your vineyard at the same time is presented in (Section H).

To continue our example spreadsheet, *Figure G-9* begins in the first column (G) Net Irrigation Requirement which was calculated in *Figure G-8*. Emitter uniformity has been measured to be an excellent 92 %. The average application rate is 0.96 gallons per emitter with one emitter per vine. The last variable to enter is the vine spacing in square feet. The spacing is 11 × 7 ft or 77 sq ft per vine. By using the calculation indicated at the top of each column of the spreadsheet, the gallons per week and the hours of operation can be determined.

Figure G-9. Irrigation Scheduling Worksheet - Lodi, CA

ETo are the averages of daily data from 1984 to 2003.  
from the Lodi (CIMIS #42) and West Lodi (#166) weather stations

Assumptions

1. Leaf Water Potential trigger was reached July 8th.
2. Harvest Date was October 1.

Date	G = [(C x D) - E - F]: Net Irrigation Requirement (in)	H = Emission Uniformity <sup>e</sup> (%)	I = G/H:Gross Irrigation Amount (in)	J = Vine Spacing <sup>f</sup> (sq feet)	K = (I x J x .623): Gallons per Vine/ Period (gal/week)	L = Average Application Rate (gph/vine)	M = (K/L): Hours of PREDICTED Irrigation Time (hours)
Jly 8-14	0.42	92	0.45	77	21.8	0.96	22.7
Jly 15-21	0.38	92	0.42	77	20.1	0.96	20.9
Jly 22-28	0.38	92	0.41	77	19.6	0.96	20.4
Jly 29 to Aug 4	0.37	92	0.40	77	19.3	0.96	20.1
Aug 5-11	0.35	92	0.38	77	18.4	0.96	19.2
Aug 12-18	0.33	92	0.36	77	17.2	0.96	17.9
Aug 19-25	0.31	92	0.33	77	16.1	0.96	16.7
Aug 26 to Sept 1	0.29	92	0.32	77	15.2	0.96	15.9
Sept 2-8	0.27	92	0.29	77	13.8	0.96	14.4
Sept 9-15	0.22	92	0.24	77	11.3	0.96	11.8
Sept 16-22	0.20	92	0.22	77	10.3	0.96	10.8
Sept 23-29	0.16	92	0.17	77	8.3	0.96	8.6
Sept 30 to Oct 6	0.66	92	0.72	77	34.5	0.96	36.0
Oct 7-13	0.60	92	0.65	77	31.3	0.96	32.6
Oct 14-20	0.53	92	0.58	77	27.6	0.96	28.8
Oct 21-27	0.45	92	0.49	77	23.4	0.96	24.4
Oct 28 to Nov 3	0.05	92	0.05	77	2.4	0.96	2.5
<b>Total</b>	<b>5.96</b>		<b>6.47</b>				
<b>Gallons per vine applied though harvest =</b>					<b>191.3</b>		
<b>Hours of irrigation time through harvest =</b>						<b>199.3</b>	

<sup>e</sup> Under deficit irrigation, Irrigation Efficiency is assumed equal to Emission Uniformity.  
<sup>f</sup> spacing 7 x 11 ft = 77 ft sq.

In our example, the 6.5 inches of water is required through the end of the season, based on an emission uniformity of 92% and an average application rate of 0.96 gallons per vine. The hours of operation would be 191 hours through harvest and a 98-hour post harvest irrigation. It should be noted that if effective rainfall occurs during the post harvest periods or if leaf drop is earlier than November 3, this amount should be reduced.

## Adjusting the Schedule for the Current Season's Climate

When real time (the current season) ETo and effective rainfall values become available, they can be substituted into the table to account for the variance from normal ETo values and the actual effective rainfall. Real time ETo and rainfall are available on a one day lag time from the CIMIS network.

The Deficit Threshold Method relies on a calculation of the historical for a one-week period, then applying the indicated amount of water to the vineyard. After the end of that week, the real time

data is downloaded and input into the spreadsheet to replace the historical ETo used to develop the last weeks schedule. Any differences between the previous week's application volume/time should be adjusted as a addition or subtraction on the new current week's schedule. For example if 12 hours were applied using the historical ETo values then upon re-calculating using real-time data the amount should have been 11 simply subtract 1 hour from the current week schedule.

In order to react to rapidly changing climate, if an extraordinary high hot and dry period begins and is expected to last a few days—increase the irrigation volume to try to meet the increase in water use. When recalculating with real time ETo values the next week's result will indicate your success in estimation.

Figure G-10 depicts the water consumed by the vineyard in our example and the sources of the water. For comparison full water is compared to the water use and sources of the deficit treatment in Figure G-11.

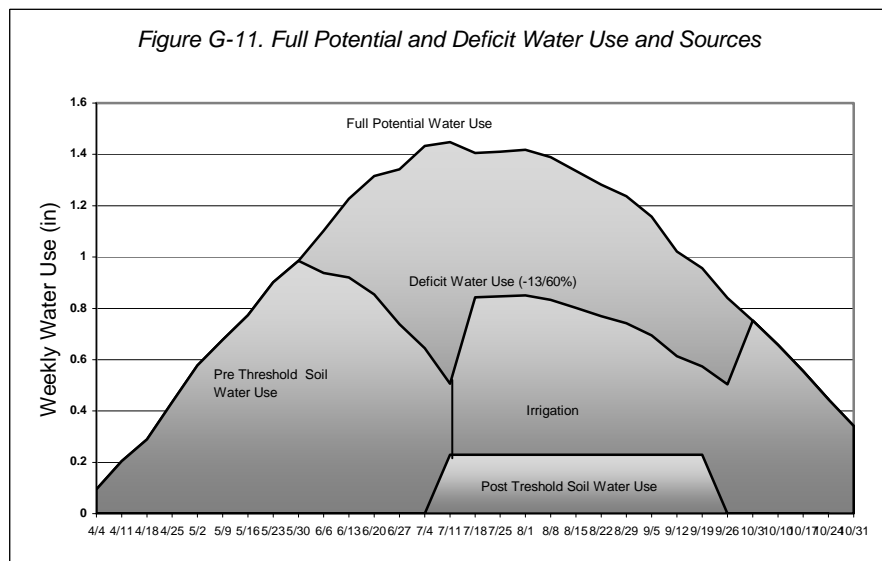
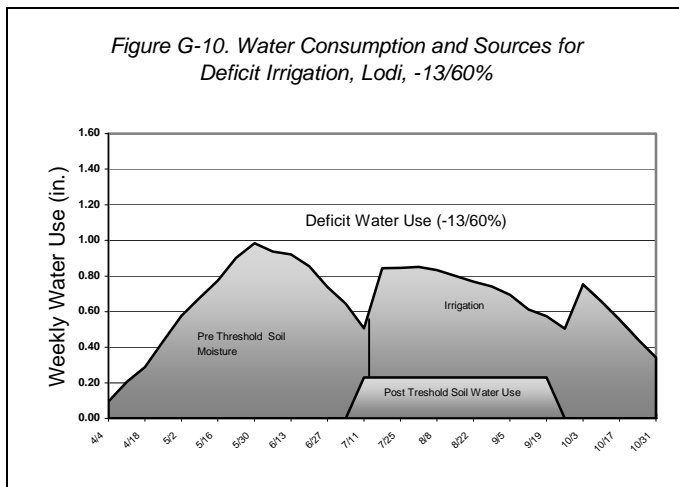

## H. Applying Irrigation Water

### *Irrigation Water Units*

The application of irrigation water is often referred to in many different units. The most universal unit is inches of water depth. It is referred to as universal since rainfall and ETo as well as the calculated irrigation volumes values use the same term. This convention allows easy manipulation of the values in making scheduling decisions. Once the scheduling decision is made, the unit “inches” must be converted to volume since emitters and water meters use “gallons” of water volume. The convention is to standardize on an area of one acre. The depth of one inch of water on an acre of land area is equal to 27154 gallons. Those familiar with their irrigation system may often use gallons per vine. It is important to note that if vineyards with a different number of vines per acre were irrigated with the same gallons per vine, the volume applied per acre would be different by the ratio of vine numbers. For a  $12 \times 7$  versus  $10 \times 7$  foot vine spacing, the ratio would be 1.2 for a 20% difference in water applied.

In this publication, the determination of how much water to apply to the vineyard is in inches of water depth for a given time period. The conversion should be first to gallons per acre. If using a water meter, multiplying the required gallons per acre by the acres irrigated provides a useful number. If using emitter discharge in gallons per hour per vine, divide the gallons per acre desired by the vines per acre to determine the irrigation volume per vine. Finally the volume of water per vine can be converted to system operation on time by dividing the gallons per vine required by the gallons per hour emitter discharge.

#### **Water Volume Conversions**

1 acre inch	=	27,154 gallons per acre
1 acre foot	=	325,000 gallons per acre
1 cubic foot	=	7.48 gallons

Often growers use gallons per vine-applied water to compare applications to fields of different vine spacing resulting in error. Additionally, the net application rate is an average over the entire vineyard without any accounting for how uniformly the water is distributed across the vineyard or without regard to irrigation efficiency. The following section describes in detail how to: 1) Determine the gross application rate and application uniformity of the drip system, and 2) Determine the number of hours to irrigate.

## Determining the Irrigation Amount

Step 1:	Determine the net amount of water you want to apply to the vineyard.
Step 2:	Determine the actual application rate and application uniformity of the drip system.
Step 3:	Determine the number of hours to irrigate.

### Step 1: Determine the vineyard's water use:

- Determine vineyard weekly net water application in inches as described in Section F. Assume for this example vineyard water use is 0.75 inch per week.
- Convert inches to gallons per acre for use with water meter  

$$\text{gallons/week/acre} = \text{net water application (in/wk)} \times 27,154 \text{ gal/ac in.}$$

Example:

$$\text{gallons per week per acre} = 0.75 \text{ in/wk} \times 27,154 = 20,366$$

- Convert inches to gallons per vine/week for use with emitter discharge  

$$\text{gallons/wk/vine} = \text{net water application (in/wk)} \times \text{vine spacing (sq. ft)} \times 0.623$$

Example:

Assume: Water application = 0.75 in/wk  
 7 ft × 11 ft vine spacing  

$$\text{gal per vine /wk} = 0.75 \text{ in/wk} \times (7 \text{ ft} \times 11 \text{ ft}) \times 0.623$$

$$= 36 \text{ gal/wk} \quad \text{or use Table H-1.}$$

**The Net Irrigation Amount is 36 gallons per vine per week.**

- Convert gallons applied to inches  

$$\text{net water application inches/wk} = \frac{\text{gallons/vine/wk}}{\text{spacing (sq ft)} \times 0.623}$$

Example:

Assume: Water application = 36 gallons/vine/wk  
 7 ft × 11 ft vine spacing  

$$\text{inches per week} = \frac{36 \text{ gallons/wk}}{(7' \times 11') \times 0.623}$$

**The Net Irrigation Amount is 0.75 inches.**

### Step 2: Determine the average application rate and application uniformity of the drip system.

- Drip emitter discharge may vary with the pressure, manufacturing variation and clogging in the drip system. For example, a 0.5 gallon per hour (gph) dripper may not actually be discharging at 0.5 gph.

- If there are multiple irrigation blocks, each block should be evaluated separately since they may be operating at different pressures.
- Sample drip emitters at the following locations. See attached forms:

- |                               |                                                                                                           |
|-------------------------------|-----------------------------------------------------------------------------------------------------------|
| <b>Head of the system</b>     | - 4 near the head of the lateral<br>- 4 near the middle of the lateral<br>- 4 near the end of the lateral |
| <b>Middle of the system</b>   | - 4 near the head of the lateral<br>- 4 near the middle of the lateral<br>- 4 near the end of the lateral |
| <b>Tail end of the system</b> | - 4 near the head of the lateral<br>- 4 near the middle of the lateral<br>- 4 near the end of the lateral |

In addition, you might sample at any other spots where you suspect there could be a difference in the pressure and discharge rate. For example, low or high elevation spots in the vineyard. More emitters than suggested above should be sampled on large irrigation blocks (greater than 20 acres).

- Collect water for 30 seconds in a 100 ml graduated cylinder (see *Table H-2*) or in a 35 mm film canister (see *Table H-3*). Use either table to convert the amount of water collected from each sampled emitter to the discharge rate for that emitter.
- The following *Example* is summarized on the attached **Sample Data Sheet**.

**A. Determine the Average Application Rate:**

- For each irrigation block, average all your discharge rate measurements. This is the average emitter discharge rate (gph) of your emitters.

*Example:* If you measured the output from 36 drip emitters, find the average discharge rate (gph) of the 36 emitters. (See **Sample Data Sheet**.)

***Average discharge rate of all emitters = 0.48 gph***

Example cont.: There are 2 drip emitters per vine

$$\begin{array}{l} \text{application rate} \\ \text{per vine (gph)} \end{array} = \begin{array}{l} 0.48 \text{ gph} \\ \text{per dripper} \end{array} \times \begin{array}{l} 2 \text{ drippers} \\ \text{per vine} \end{array} = \mathbf{0.96 \text{ gph/vine}}$$

***Average Application Rate is 0.96 gph/vine:***

## B. Determine the Emission Uniformity:

Each drip emitter in the vineyard will be discharging water at a different rate. This discharge variability is due to manufacturing variation between emitters, pressure differences in the system, and any emitter clogging which may be occurring. We need to compensate for the variability when we determine how much to irrigate (gross irrigation application).

The drip system's application uniformity is quantified using a measurement called the Emission Uniformity (sometimes referred to as the Distribution Uniformity). The Emission Uniformity (EU) is defined as:

$$\text{Emission Uniformity (\%)} = \frac{\text{Avg. discharge rate of the low 25\% sampled emitters}}{\text{Avg. discharge rate of all the sampled emitters}} \times 100$$

To determine the average discharge rate of the low 25% of sampled emitters, the discharge rate (gph) of each of the sampled emitters should be ranked from lowest to highest and the 25% of the emitters with the lowest discharge rate should be averaged together. For example, if 36 emitters were monitored, the average of the 9 emitters with the lowest discharge rates would be determined.

*Example cont.: Average discharge rate of all sampled emitters = 0.48 gph*

*Average discharge rate of the low 25% sampled emitters = 0.44 gph*

$$\text{Emission Uniformity (\%)} = \frac{0.44 \text{ gph}}{0.48 \text{ gph}} \times 100 = 92\%$$

**Average Emission Uniformity is 92%** (This is quite good)

### ***Step 3: Determine the number of hours to irrigate:***

The gross irrigation amount (the amount you actually apply) should include the net water you wish to apply plus some additional water to account for the inefficiencies of the irrigation system. The gross irrigation amount is determined as:

$$\text{Gross irrigation amount} = \frac{\text{Net irrigation amount}}{\text{Irrigation efficiency (\%)}} \times 100$$

Irrigation efficiency is difficult to quantify. However, when using micro irrigation techniques, if the drainage below the root zone and the runoff from irrigation is minimal, then the irrigation efficiency can be approximated using the emission uniformity. The above equation becomes:

$$\text{Gross irrigation amount} = \frac{\text{Net irrigation amount}}{\text{Emission uniformity (\%)}} \times 100$$

*Example cont.:* Net irrigation amount = 36 gal per vine/wk (see Step 1)  
 Avg. application rate per vine = 0.96 gph (Step 2A)  
 Emission uniformity = 92% (see Step 2B)

$$\text{Gross irrigation amount} = \frac{36 \text{ gal/wk}}{92} \times 100 = 39 \text{ gal/wk}$$

$$\text{irrigation time per week (hrs)} = \frac{\text{gross irrigation amount (gal/wk)}}{\text{avg. application rate per vine (gph)}}$$

$$\frac{39 \text{ gallons/wk}}{0.96 \text{ gph}} = 41 \text{ hrs}$$

**Number of hours to irrigate is 41 hours/week.**

*Table H-1. Converting vineyard water use from inches/week to vine water use in gallons per vine / week for various vine spacings.*

		Vineyard water use (inches/week)										
		0.40	0.50	0.60	0.70	0.75	0.80	0.90	1.00	1.10	1.20	1.30
<b>Vine Spacing</b>	<b>4' × 7'</b>	7.0	8.7	10.5	12.2	13.1	14.0	15.7	17.5	19.2	20.9	22.7
	<b>5' × 8'</b>	10.0	12.5	15.0	17.5	18.7	19.9	22.4	24.9	27.4	29.9	32.4
	<b>5' × 10'</b>	12.5	15.6	18.7	21.8	23.4	24.9	28.1	31.2	34.3	37.4	40.5
	<b>6' × 8'</b>	12.0	15.0	18.0	20.9	22.4	23.9	26.9	29.9	32.9	35.9	38.9
	<b>6' × 10'</b>	15.0	18.7	22.4	26.2	28.1	29.9	33.7	37.4	41.1	44.9	48.6
	<b>7' × 10'</b>	17.5	21.8	26.2	30.5	32.7	34.9	39.3	43.6	48.0	52.4	56.7
	<b>7' × 11'</b>	19.2	24.0	28.8	33.6	36.0	38.4	43.2	48.0	52.8	57.6	62.4
	<b>8' × 10'</b>	19.9	24.9	29.9	34.9	37.4	39.9	44.9	49.9	54.9	59.8	64.8
	<b>8' × 12'</b>	23.9	29.9	35.9	41.9	44.9	47.9	53.9	59.8	65.8	71.8	77.8

*Table H-2. Drip emitter discharge rate (gallons per hour- gph using a graduated cylinder.*

ml of water collected in 30 seconds	Drip emitter discharge rate (gph)	ml of water collected in 30 seconds	Drip emitter discharge rate (gph)
10	0.32	26	0.82
12	0.38	28	0.89
14	0.44	30	0.95
16	0.51	32	1.01
18	0.57	34	1.08
20	0.63	36	1.14
22	0.70	38	1.20
24	0.76	40	1.27

$$\text{Drip emitter discharge rate (gal/hr)} = \frac{\text{Water (ml) collected in 30 seconds}}{1000} \times 0.0317$$

*Table H-3. Drip emitter discharge rate (gallons per hour - gph) using a 35 mm film canister*

Seconds to fill 35 mm film canister	Drip emitter discharge rate (gal/hr)	Seconds to fill 35 mm film canister	Drip emitter discharge rate (gal/hr)
26	1.28	50	0.67
28	1.19	52	0.64
30	1.11	54	0.62
32	1.04	56	0.59
34	0.98	58	0.57
36	0.92	60	0.55
38	0.88	62	0.54
40	0.83	64	0.52
42	0.79	66	0.50
44	0.76	68	0.49
46	0.72	70	0.48
48	0.69		

$$\text{Drip emitter discharge rate (gal/hr)} = 33.29 \div \text{Time to fill 35 mm film canister (seconds)}$$

## I. Monitoring Vine Performance to Evaluate Strategy

Measuring vine performance makes it possible to improve the irrigation both during the current year and for the following season. Post threshold measurements of leaf water potential and vegetative growth can be made during the season. Fruit quality, yield components, and maximum shoot length and pruning weights can be measured at harvest.

### *Post Threshold Midday Leaf Water Potential*

Using the deficit threshold method, measurements of vine water status are made to determine when to begin irrigation. The pressure chamber can also be used to monitor the vine water status as it is influenced by the irrigation amounts determined by the RDI %. The time to measure vine water status, which is most meaningful, is just before an irrigation event. This measures the maximum water stress before the next irrigation. *Figure H-1* shows the leaf water potential of various irrigation regimes before and after weekly irrigation began. Post threshold monitoring can be used to determine the effect of the irrigation amounts and to validate the RDI %. Changes can be made to the irrigation volumes if results are inconsistent with expectations. Note that there can be a lag in leaf water potential recovery after significant water deficits as shown after irrigation began in Treatment 4 (*Figure I-1*).

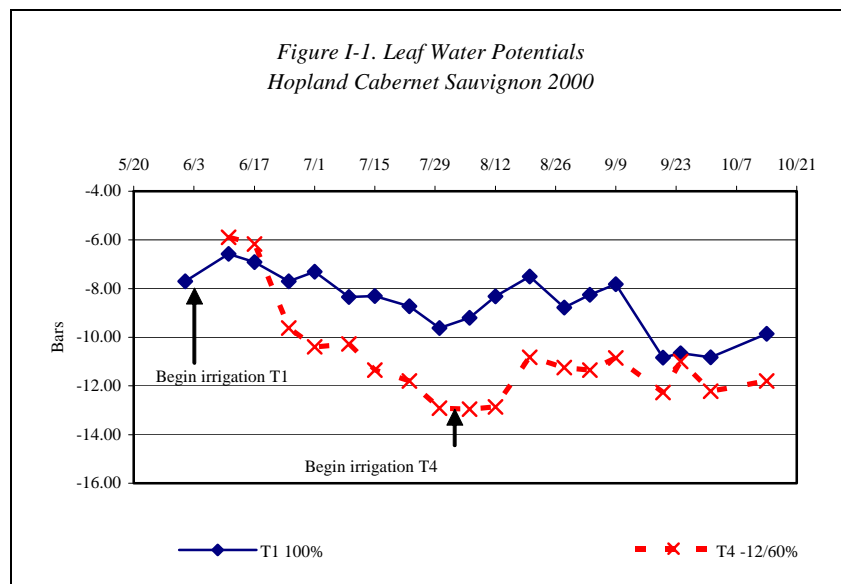

## Vegetative Growth

Shoot length measurements are the most common evaluation of vegetative growth. They can be made at harvest (pre hedging) or at pruning if there is no hedging before harvest. Shoots can be measured in a two-week frequency to determine the rate of shoot growth (see *Chapter F, Determining When to Irrigate*). Measurement shoots are selected early in the season by flagging the shoots from the same relative cordon position on a number of vines in an irrigation block. The number can vary but typical is 2 shoots per vine with 2 vines per site and at least 3 sites per block. Shoot growth is quite variable, so more measurements will give a better estimate of the average.

Pruning weights are also a good indication of vegetative growth when not hedged at harvest. Typically, the pruning weights of 10 vines per site and 3 sites per block are necessary to achieve a reasonable average. Measurement of spur diameter between the 1<sup>st</sup> and 2<sup>nd</sup> buds left on a spur is also gaining popularity since pre-harvest is becoming commonplace.

## Yield

### Yield

Yield is typically recorded as the delivered fruit from a block. It is important to keep blocks irrigated by different strategies separate to evaluate the effect of an irrigation regime. Berry size is an important yield component, which determines the ultimate yield. It is often the most important factor in yield differences in deficit irrigation studies. *Figure I-2* shows the average relationship between berry size and the portion of full water use (applied water) from six vineyards in 1998 (from L.E. Willams 1998). Berry weight was 97% of maximum at 0.75 of full potential water use.

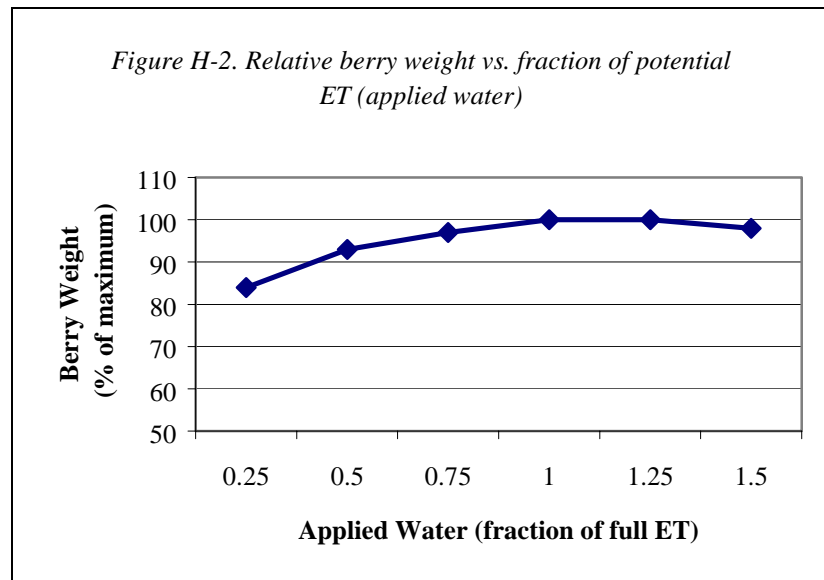

## *Fruit Quality*

Visual estimates of fruit quality include the amount of sunburn, shrivel, and rot. Fruit quality can be assessed by measuring soluble solids (°Brix), pH, titratable acidity (TA), and Malic acid content. Each of these measurements along with the comments from the winemaker should be used to evaluate the success of any irrigation regime.

# Appendix

## Drip System Evaluation Form

Sampled drip emitter	Location	Water (ml) collected in 30 seconds	Emitter discharge rate (gph)	Ranking
1	_____	_____	_____	_____
2	_____	_____	_____	_____
3	_____	_____	_____	_____
4	_____	_____	_____	_____
5	_____	_____	_____	_____
6	_____	_____	_____	_____
7	_____	_____	_____	_____
8	_____	_____	_____	_____
9	_____	_____	_____	_____
10	_____	_____	_____	_____
11	_____	_____	_____	_____
12	_____	_____	_____	_____
13	_____	_____	_____	_____
14	_____	_____	_____	_____
15	_____	_____	_____	_____
16	_____	_____	_____	_____
17	_____	_____	_____	_____
18	_____	_____	_____	_____
19	_____	_____	_____	_____
20	_____	_____	_____	_____
21	_____	_____	_____	_____
22	_____	_____	_____	_____
23	_____	_____	_____	_____
24	_____	_____	_____	_____
25	_____	_____	_____	_____
26	_____	_____	_____	_____
27	_____	_____	_____	_____
28	_____	_____	_____	_____
29	_____	_____	_____	_____
30	_____	_____	_____	_____
31	_____	_____	_____	_____
32	_____	_____	_____	_____
33	_____	_____	_____	_____
34	_____	_____	_____	_____
35	_____	_____	_____	_____
36	_____	_____	_____	_____

Avg. discharge rate of all sampled emitters = \_\_\_\_\_ gph

Avg. discharge rate of the low 25% of sampled emitters = \_\_\_\_\_ gph

$$\begin{aligned} \text{Emission Uniformity (\%)} &= \frac{\text{Avg. discharge rate of the low 25\% sampled emitters}}{\text{Avg. discharge rate of all the sampled emitters}} \times 100 \\ &= \text{_____} \times 100 = \text{_____ \%} \end{aligned}$$

## Sample Data Sheet Drip System Evaluation Form

Sampled drip emitter	Location	Water (ml) collected in 30 seconds	Emitter discharge rate (gph)	Ranking
1		17	0.54	31
2		14	0.44	3
3		15	0.48	10
4		16	0.51	24
5		15	0.48	11
6		17	0.54	32
7		15	0.48	12
8		16	0.51	25
9		14	0.44	4
10		17	0.54	33
11		17	0.54	34
12		15	0.48	14
14		15	0.48	13
15		16	0.51	26
16		14	0.44	6
17		15	0.48	15
18		16	0.48	16
19		13	0.41	1
20		15	0.48	17
21		14	0.44	7
22		15	0.48	18
23		16	0.51	27
24		13	0.41	2
25		17	0.54	35
26		15	0.48	19
27		16	0.51	28
28		14	0.44	8
29		15	0.48	20
30		15	0.48	21
31		17	0.54	36
32		16	0.51	29
33		15	0.48	22
34		16	0.51	30
35		14	0.44	9
36		15	0.48	22

**Avg. discharge rate of all sampled emitters = 0.48 gph**

**Avg. discharge rate of the low 25% of sampled emitters = 0.44 gph**

$$\text{Emission Uniformity (\%)} = \frac{\text{Avg. discharge rate of the low 25\% sampled emitters}}{\text{Avg. discharge rate of all the sampled emitters}} \times 100$$

$$\text{Emission Uniformity (\%)} = \frac{0.44}{0.48} \times 100 = 92\%$$

**Average Weekly Non-Rain Eto  
Lodi, CA CIMIS Stations # 42 and #166**

	Inches		Inches
January 1-7	0.19	July 1-7	1.86
January 8-14	0.20	July 8-14	1.82
January 15-21	0.29	July 15-21	1.72
January 22-28	0.30	July 22-28	1.69
January 29-February 4	0.34	July 29 to August 4	1.68
February 5-11	0.40	August 5-11	1.63
February 12-18	0.56	August 12-18	1.56
February 19-25	0.63	August 19-25	1.49
February 26-March 3	0.61	August 26 to September 1	1.45
March 4-10	0.71	September 2-8	1.37
March 11-17	0.80	September 9-15	1.23
March 18-24	0.93	September 16-22	1.17
March 25-31	1.10	September 23-29	1.05
April 1 - 7	1.14	September 30 to October 6	0.97
April 8-14	1.28	October 7-13	0.88
April 15-21	1.24	October 14-20	0.78
April 22-28	1.43	October 21-27	0.66
April 29-May 5	1.57	October 28 to November 3	0.54
May 6-12	1.58	November 4 to 10	0.50
May 13-19	1.59	November 11 to 17	0.40
May 20-26	1.67	November 18-24	0.32
May 27-June 2	1.67	November 25-December 1	0.34
June 3-9	1.74	December 2-8	0.26
June 10-16	1.82	December 9-15	0.24
June 17-23	1.85	December 16-22	0.22
June 24-30	1.80	December 23-29	0.21
		December 30-31(partial week)	0.05

### Sample Irrigation Scheduling Worksheet -

	<b>A =</b>	<b>B =</b>	<b>C =</b>	<b>D =</b>	<b>E =</b>	<b>F =</b>	<b>G =</b>	<b>H =</b>	<b>I =</b>	<b>J =</b>	<b>K =</b>	<b>L =</b>	<b>M =</b>
<b>Date</b>	<b>Historical Eto<sup>a</sup></b>	<b>Crop Coefficient<sup>b</sup></b>	<b>A x B: Potential Water Use</b>	<b>RDI Coefficient<sup>c</sup></b>	<b>Soil Contribution</b>	<b>Effective Rainfall<sup>d</sup></b>	<b>[(C x D) - E - F]: Net Irrigation Requirement</b>	<b>Emission Uniformity<sup>e</sup></b>	<b>G/H: Gross Irrigation Amount</b>	<b>Vine Spacing<sup>f</sup></b>	<b>x J x .623): Gallons per Vine/ Period</b>	<b>Average Application Rate</b>	<b>(K/L): Hours of PREDICTED Irrigation Time</b>
<b>Period</b>	<b>Inches/Period</b>	<b>Kc</b>	<b>(in)</b>	<b>RDI %</b>	<b>(in)</b>	<b>(in)</b>	<b>(in)</b>	<b>(%)</b>	<b>(in)</b>	<b>(sq feet)</b>	<b>(gal/week)</b>	<b>(gph/vine)</b>	<b>(hours)</b>
Jly 8-14													
Jly 15-21													
Jly 22-28													
Jly 29 to Aug 4													
Aug 5-11													
Aug 12-18													
Aug 19-25													
Aug 26 to Sept 1													
Sept 2-8													
Sept 9-15													
Sept 16-22													
Sept 23-29													
Sept 30 to Oct 6													
Oct 7-13													
Oct 14-20													
Oct 21-27													
Oct 28 to Nov 3													
<b>Total</b>													

Gallons per vine applied though harvest =

Hours of irrigation time through harvest =

**Sample Irrigation Scheduling Worksheet - Lodi, CA**  
 ETo and precipitation are the averages of daily data from 1984 to 2003.  
 Data from the Lodi (CIMIS #42) and West Lodi (#166) weather stations

Assumptions

1. Leaf Water Potential trigger was reached July 8th.
2. Harvest Date was October 1.

Date	A = Historical Eto <sup>a</sup> Inches/Period	B = Crop Coefficient <sup>b</sup> Kc	C = A x B: Potential Water Use (in)	D = RDI Coefficient <sup>c</sup> RDI %	E = Soil Contribution (in)	F = Effective Rainfall <sup>d</sup> (in)	G = [(C x D) - E - F]: Net Irrigation Requirement (in)	H = Emission Uniformity <sup>e</sup> (%)	I = G/H:Gross Irrigation Amount (in)	J = Vine Spacing <sup>f</sup> (sq feet)	K = J x J x .623): Gallons per Vine/ Period (gal/week)	L = Average Application Rate (gph/vine)	M = (K/L): Hours of PREDICTED Irrigation Time (hours)
Jly 8-14	1.82	0.68	1.24	0.5	0.2	0	0.42	92	0.45	77	21.8	0.96	22.7
Jly 15-21	1.720	0.68	1.17	0.5	0.2	0	0.38	92	0.42	77	20.1	0.96	20.9
Jly 22-28	1.692	0.68	1.15	0.5	0.2	0	0.38	92	0.41	77	19.6	0.96	20.4
Jly 29 to Aug 4	1.676	0.68	1.14	0.5	0.2	0	0.37	92	0.40	77	19.3	0.96	20.1
Aug 5-11	1.626	0.68	1.11	0.5	0.2	0	0.35	92	0.38	77	18.4	0.96	19.2
Aug 12-18	1.556	0.68	1.06	0.5	0.2	0	0.33	92	0.36	77	17.2	0.96	17.9
Aug 19-25	1.494	0.68	1.02	0.5	0.2	0	0.31	92	0.33	77	16.1	0.96	16.7
Aug 26 to Sept 1	1.448	0.68	0.98	0.5	0.2	0	0.29	92	0.32	77	15.2	0.96	15.9
Sept 2-8	1.368	0.68	0.93	0.5	0.2	0	0.27	92	0.29	77	13.8	0.96	14.4
Sept 9-15	1.225	0.68	0.83	0.5	0.2	0	0.22	92	0.24	77	11.3	0.96	11.8
Sept 16-22	1.171	0.68	0.80	0.5	0.2	0	0.20	92	0.22	77	10.3	0.96	10.8
Sept 23-29	1.054	0.68	0.72	0.5	0.2	0	0.16	92	0.17	77	8.3	0.96	8.6
Sept 30 to Oct 6	0.974	0.68	0.66	1		0	0.66	92	0.72	77	34.5	0.96	36.0
Oct 7-13	0.883	0.68	0.60	1		0	0.60	92	0.65	77	31.3	0.96	32.6
Oct 14-20	0.779	0.68	0.53	1		0	0.53	92	0.58	77	27.6	0.96	28.8
Oct 21-27	0.660	0.68	0.45	1		0	0.45	92	0.49	77	23.4	0.96	24.4
Oct 28 to Nov 3	0.540	0.68	0.37	1		0.32	0.05	92	0.05	77	2.4	0.96	2.5
<b>Total</b>			<b>14.75</b>		<b>2.40</b>		<b>5.96</b>		<b>6.47</b>				

<sup>a</sup> <http://www.cimis.water.ca.gov/cimis> or <http://ucipm.ucdavis.edu>

<sup>b</sup> Crop Coefficient calculated based on 40% midday land surface shaded (0.68)

<sup>c</sup> Regulated Deficit is 50% (0.5)

<sup>d</sup> Effective rainfall is calculated from actual rainfall. Calculations are not shown on this sheet.

<sup>e</sup> Under deficit irrigation, Irrigation Efficiency is assumed equal to Emission Uniformity.

<sup>f</sup> spacing 7 x 11 ft = 77 ft sq.

Gallons per vine applied though harvest = 191.3

Hours of irrigation time through harvest = 199.3